

## Plates for pad printing



Print-ready clichés  
Plates for exposure  
Accessories for cliché production  
Reprography-service

## Content

	Page
Range of plate types	4
Plastic plates	5
Steel plates	6
Steel plates 05	7
Ceramic plates	8
Overview lifetime	9
Plate sizes, fixing holes, punching	10
Plate sizes	11
Part numbers	12
Printing mats	13
Exposure units und drying cabinets	14
Accessories for cliché exposure	15
Film- and cliché service	16/17
Laser engraving	18
Further information	19

Clichés play an important role in pad printing as they hold the print image that is transferred by the pad to the object. The quality of the plate and the print image affect the quality of the print directly.

Since the founding of Teca-Prints over 40 years ago, the choice of plates and the etching or exposure of plates have permanently and consistently been developed.

You can rely on our experience and our expert advice.

This brochure is a collection of important information about plates.



## Overview plate types

Teca-Print only offers plates that are suitable for pad printing.  
The range of plates includes the following types:

- Plastic plates
- Steel plates
- Steel plates 05
- Ceramic plates

Within the different plate types there are many further divisions, so that there is a suitable plate for each application and machine fitting.

For all plate types Teca-Print offers you competent advice by a motivated team of employees with many years' knowledge in pad printing.



Plastic plates are used for many different applications in pad printing. They are cost-effective and offer high flexibility thanks to the quick and easy exposure options. Especially for small and medium-sized print series plastic plates have become indispensable. Plastic plates are made of thin metal carrier plates that are covered with a UV light-sensitive plastic coating.

Depending on the type of application different plastic plate types can be used:

### Plastic plates water washable standard

Name: I18 (unpunched)  
Appearance: yellowish green  
Recommended for: open inking system

- good plate for many applications
- environment-friendly, because it is water washable
- ideal for small and medium-sized print series



### Plastic plates alcohol washable SimpleX

Name: B15 (unpunched)  
Appearance: black  
Recommended for: open inking system

- good plate for many applications
- ideal for small and medium-sized print series



### Plastic plates alcohol washable Long-Life

Name: K52 (unpunched)  
G52 (punched 2 holes)  
G53 (punched 4 holes)  
Appearance: red-orange  
Recommended for: open and sealed inking system

- robust, universally usable plate for many applications
- can be used with an open as well as a sealed inking system
- ideal for medium-sized print series



## Steel plates

Steel plates are made of high-quality special steel (hardness approx. 65 Rc). The thickness of the steel plates normally is approx. 10 mm, though for smaller machines plates with a thickness of 6 or 8 mm can also be used. Because of the high abrasion resistance these plates are ideal for large print series.

Teca-Print-steel plates are coated with a light-sensitive layer for etching.

As special editions you can also get steel plates with a polished surface and steel plates with chrome steel parts at Teca-Print.

As the material costs of steel plates can not be ignored, Teca-Print offers a grinding and lapping service for used plates: the steel plates are grinded and newly coated, so that it can be used for the next etching.

### Steel plates

Name: S98 (Thickness 10 mm, coated)  
S99 (Thickness 10 mm, coated with fixing hole on the front side)  
S58 (Thickness 06 mm, coated)  
S78 (Thickness 08 mm, coated)

Appearance: steel-coloured

Recommended for: open and sealed inking system

- plate made of high-quality steel
- reuseable after grinding and lapping service
- ideal for large series

### Polished steel plates

Name: S98P (polished surface)  
S98PQ (polished surface and plate outside smoothed)  
Polished and smoothed steel plates with a thickness of 6 or 8 mm are also available.

Appearance: high-gloss

Recommended for: open and sealed inking system

- plates made of high-quality, polished steel
- ideal for finest print images

### Chrome steel plates (available on request)

Name: A98 (Thickness 10 mm, coated)  
A99 (Thickness 10 mm, coated with fixing hole on the front side)

Appearance: steel-coloured

Recommended for: open and sealed inking system

- special feature in regard of steel plates
- highly corrosion-resistant
- ideal for large series



Steel plates 05 are plates made of thin steel (thickness approx. 0,5 mm). They have a light-sensitive coating like normal steel plates and undergo the same etching process.

Teca-Print offers two types of steel plates 05:

Ecoprint-steel plates 05 have a polished surface. The good cost-performance ratio makes these plates popular for many different applications.

Recoprint-steel plates 05 are lapped in addition, so that the surface structure is equivalent to the thicker steel plates.

### Steel plates 05 Ecoprint

Name: E050 (unpunched)  
E052 (punched 2 holes)  
E054 (punched 4 holes)  
Appearance: steel-coloured, slightly shiny  
Recommended for: open and sealed inking system

- in many cases the cost-effective alternative to thick steel plates
- ideal for medium-sized series

### Steel plates 05 Recoprint

Name: R050 (unpunched)  
R052 (punched 2 holes)  
R054 (punched 4 holes)  
Appearance: steel-coloured  
Recommended for: open and sealed inking system

- finer surface, same surface structure as the thick steel plates
- ideal for medium-sized series



## Ceramic plates

Ceramic plates are plates made only of ceramic. These offer an interesting alternative to the common plastic- and steel plates. They are usually used when a particularly long lifetime is required and only the slightest abrasion can be tolerated.

The engraving is done by laser. The significantly deeper etch depth, that is possible with laser engraving, offers the transfer not only of ink but also other mediums such as glue or medias with high pigmentation. Ceramic plates are also preferable for abrasive transfer mediums.

### Ceramic plates

Name:	U06 (thickness 06 mm) U10 (thickness 10 mm)
Appearance:	white
Recommended for:	open and sealed inking system In sealed inking systems we recommend the use of ink cups with steel ring blades.

- long lifetime
- for applications that require a deep etching depth
- ideal also for abrasive transfer mediums
- unproblematic storage of the plates

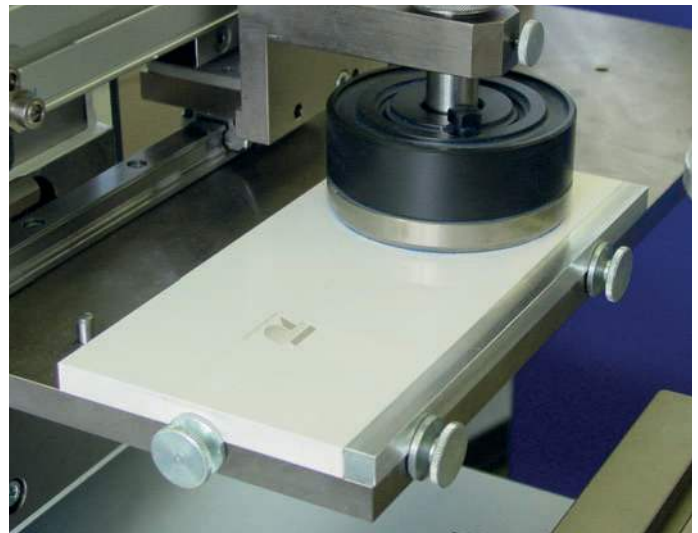



The lifetime of the plate is measured by the possible number of times the blade can draw back the ink, this is the production output. The table below shows the reference values for the max. lifetime of each plate type.

Attention: The lifetime of a plate depends on many different factors.

These include blade contact pressure in open inking systems and in closed systems contact pressure of the ink cup. Additionally the ink type and the colour have effects, as also the care of the plate.

	approx. estimate of the max. lifetime				
	3 mio.	1 mio.	100'000	25'000	10'000
Plastic plate standard I18					X
Plastic plate B15 SimpleX					X
Plastic plate Long-Life				X	
Steel plate S98, S99, S58, S78		X			
Chrome steel plate A98, A99		X			
Steel plate 05 Ecoprint			X		
Steel plate 05 Recoprint			X		
Ceramic plate	X				

Important Note: Our table shows guide values that can be exceeded or fall below the given figures.



## Plate sizes, fixing holes, punching

All plate types are available in different sizes. Depending on the mounting method of the plate in the machine several types of fixing holes and punching can be ordered.

With an open inking system Teca-Print pad printing machines do not need fixing holes or punched holes to attach the cliché to the magnetic plate respectively to the plateholder.

With a closed inking system the plastic plates and steel plates 05 usually have punched holes. Depending on the machine type the plates have 2 or 4 fixing holes to mount the plate.

Steel plates that are used in a sealed inking system partially have frontal fixing holes.

Teca-Print also offers plates for other pad printing machines in the size required and with the appropriate punched holes.

### Plastic plates and steel plates 05

For plastic plates and steel plates 05 Teca-Print offers a cutting service. That means we cut the plate to the exact size needed. Naturally the necessary punched holes are also part of our service.

Unexposed or unetched plastic plates are available in practical packages of 10 pieces and steel plates 05 in packages of 5 pieces.

### Steel plates

We also have a wide range of steel plates in numerous sizes. Steel plates are always sold individually regardless if the plate is ordered etched or unetched.

### Ceramic plates

Despite its many advantages, ceramic plates are only used by few customers at present.

We are happy to offer you the ceramic plates in the fitting plate size.

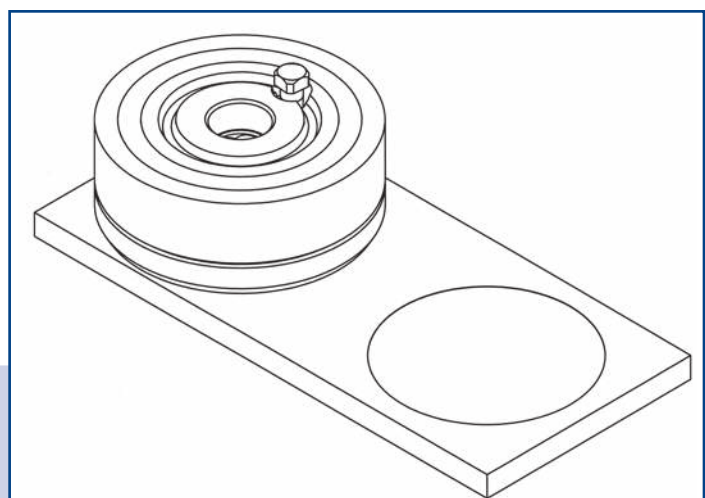

Tip: This is how you can calculate the ideal cliché depth with a sealed inking system:  
 $\text{Ø ink cup} \times 2 \text{ plus } 25\text{-}40 \text{ mm}$

Due to the many different plate sizes that are available it is impossible to list all sizes. The following overview shows examples of the most common plate sizes.

plate width in mm	plate depth in mm
60	60
	140
70	140
80	80
	150
	180
	200
	220
100	50
	60
	80
	100
	200
	220
120	80
	100
	120
130	200
	220
	320
160	100
	110
	120
180	120
	150
	405
200	90
	100
	150
	200

plate width in mm	plate depth in mm
250	50
	100
	120
	140
	150
	180
	200
	220
	250
	260
350	320
	100
	120
	140
	180
	220
	250
450	260
	270
	320
	100
	120
	150
	180
600	200
	220
	270
	150
600	180
	200
	200

This table only shows a few examples.  
Naturally there are many further plate sizes available.

## Part numbers

Teca-Print has an easy and quick system to find the right part number for plates. The self-explanatory part number consists of the name of the plate type plus the size of the plate.

The size is given in mm and is always width x depth.

The name of the plate type can be found on pages 5 to 8.

Example:

Plastic plate standard, unpunched, water washable in size 250 x 100 mm:  
part number I18 250 100

Plastic plate Long-Life, punched 2 holes, alcohol washable in size 350 x 220 mm:  
part number G52 350 220

Steel plate, thickness 10 mm, coated, in size 450 x 100 mm:  
part number S98 450 100

Steel plate 05 with lapped surface and punched 4 holes in size 100 x 220 mm:  
part number R054 100 220



Note:

The plate depth is always the side with the movement direction of the ink cup or blade.

Exception: systems with lateral slide



Printing mats are recommended for applications with a closed inking system if a plastic plate or a steel plate 05 is used. The mat is made of polyfibron and is soft but very durable and the sticky side is placed on the insertion plate.

Advantages of a printing mat:

- improved performance of the ink cup
- neutralization of irregularities
- increased plate lifetime

The rubber printing mat is cut to size by the user. The basic format is available in three different measurements.



Article number	Name	Size
59757 0004	printing mat	250 x 500 mm
59757 0005	printing mat	250 x 1000 mm
59757 0003	printing mat	500 x 1000 mm



## Exposure units and drying cabinets

With Teca-Print exposure units plastic plates and steel plates 05 can be exposed easily and reliably. The compact devices have UV lamp and an integrated vacuum pump. The exposure time is set with a timer. Depending on the plate size exposure units in three different sizes are available.

For the ideal curing process of plastic plates and the achievement of the maximal lifetime we recommend a drying cabinet. The devices also have UV lamp and can reach a drying temperature of up to 60°C. The time required for the curing can easily be set via timer. After the expiration the heat supply turns off automatically.

Part number	Name	Max. plate size
90 00 53	Exposure unit BG 25/30	350 x 220 mm
90 00 07	Exposure unit BG 35/50	620 x 270 mm
90 00 55	Exposure unit BG 35/100	1100 x 350 mm



Part number	Name	Max. plate size
90 00 54	Drying cabinet TS 25/30	350 x 220 mm
90 00 06	Drying cabinet TS 35/50	600 x 250 mm
90 00 56	Drying cabinet TS 35/100	1300 x 450 mm



Apart from the exposure units and drying cabinets different accessories make the production of clichés even easier. All items are optimally adapted for the usage in pad printing and used daily at Teca-Print.



Screened film with 120 lines/cm for the exposure of plastic plates

Part number	Name	Size
90 00 23	Screened film E7812	180 x 130 mm
90 00 24	Screened film E7812	600 x 166 mm

Screened film with 80 lines/cm for the exposure of plastic plates

Part number	Name	Size
90 00 21	Screened film D7580	180 x 130 mm
90 00 22	Screened film D7580	600 x 166 mm

Further types and sizes of screened films are available.

Screened film with 80 lines/cm for the exposure of steel plates 05

Part number	Name	Size
90 00 27	Screened film F6380	180 x 130 mm
90 00 28	Screened film F6380	600 x 166 mm



Part number	Name	Size, unit
90 01 50	Washout solvent	1 litre
90 01 30	Washout tray with magnet foil	250 x 150 mm
90 01 32	Washout tray with magnet foil	439 x 389 mm
90 01 31	Washout tray with magnet foil	619 x 189 mm
90 01 40	Plush-cloth rubber	1 piece
90 01 11	Replacement plush-cloth	1 piece
55796 0005	All-purpose tissues	box à 912 pieces
55796 0006	All-purpose tissues	pack à 76 pieces



## Film- and Cliché service

Teca-Print offers a professional reprographic and cliché service for all plate types.

Our experienced employees in the reprographic department have high quality equipment to produce an optimized film for pad printing. The complete data can be delivered in the data format \*.ai, \*.eps or \*.pdf. Line graphics should be vectorized and fonts should be converted into paths, alternatively please deliver all font styles.

If a complete graphic is not available we are happy to take over the creation of the data for the printing image.

We will wait for your approval of the print proof before we produce the cliché.

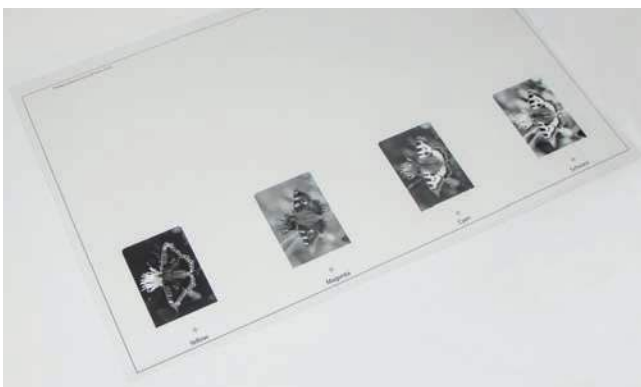





After the film production Teca-Print offers to carry out the light exposure respectively the etching of the plate for you.

For the production of plastic plates, steel plates and steel plates 05 the latest equipment is used. The combination of high-performance technology and our long-standing experienced employees guarantee a professional realisation of your cliché.

By the way: We are happy to file the film data made for you for a duration of up to 5 years.

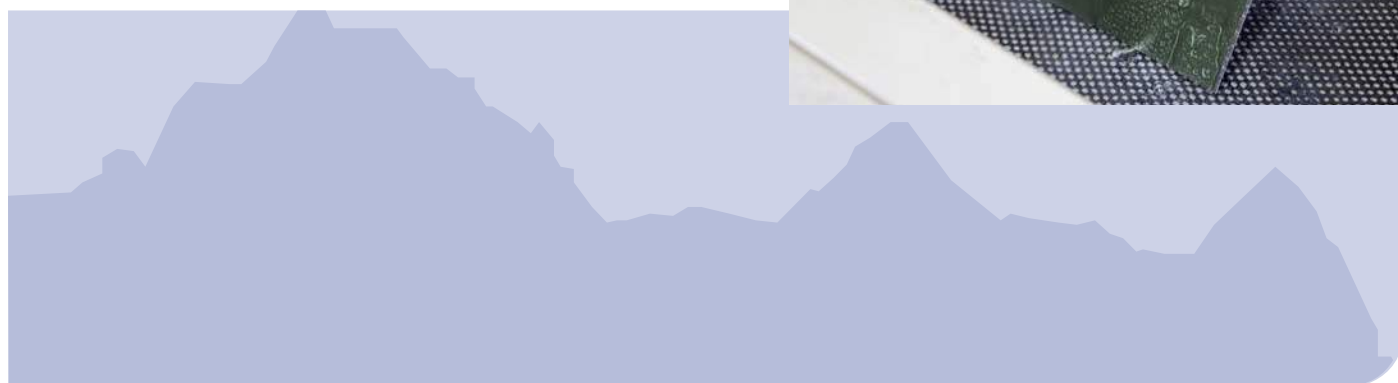
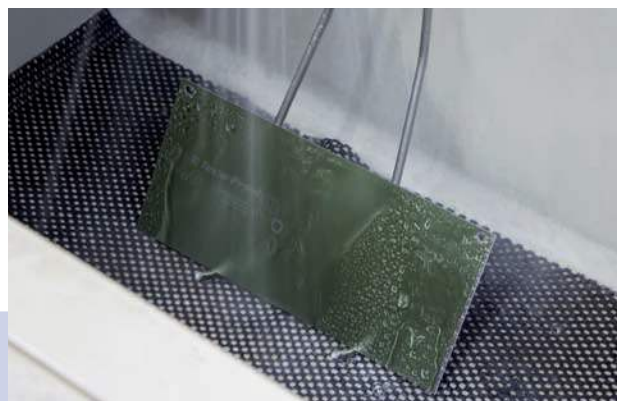

## Laser engraving

Ceramic plates are engraved with lasers.

For laser engraving digital data is needed. The data we receive is thoroughly checked before starting the laser process.

Suitable data formats for laser engraving are:

\*.dxf, \*.pdf, \*.eps, \*.ai.

Line graphics should be vectorized and fonts should be converted into paths, alternatively please deliver all font styles.

Our reprographic department is also happy to create data for laser engraving for you.

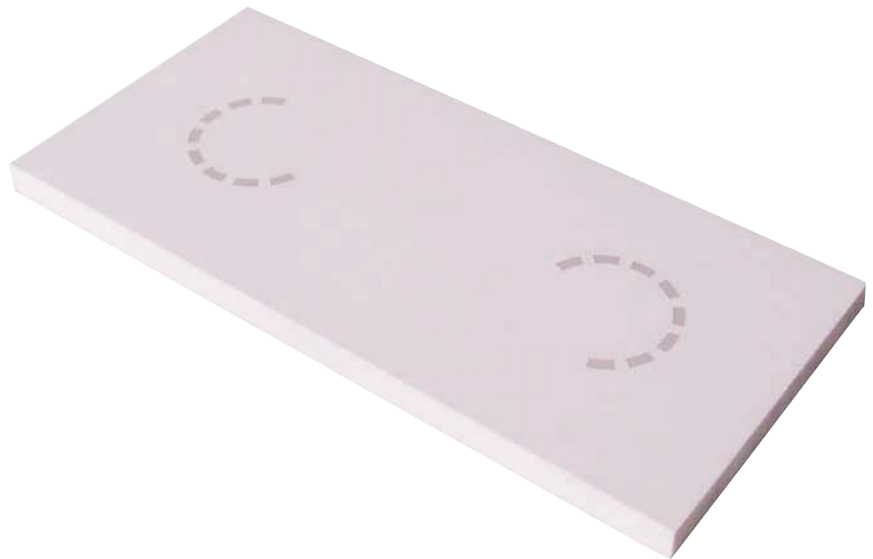

Further information can be found in our brochures on clichés and about pad printing.

Regarding the exposure of plastic plates we can give you a data sheet with valuable hints on cliché exposure and the recommended exposure- and curing times.

We would be happy to welcome you in Thayngen for our pad printing workshop. During our 2 day workshop we convey theoretical and practical knowledge. At the same time you receive valuable tips that can not be found in specialised books. Profit from our experience to be ahead of your competitors. Small groups of maximum 10 participants give us the flexibility to respond to the wishes of the group. The dates of the courses can be found at [www.teca-print.com](http://www.teca-print.com).



Please also visit our website [www.teca-print.com](http://www.teca-print.com).

Here you can find further information and our brochures and product overviews can be downloaded directly.

The logo for Teca-Print, featuring a stylized blue icon of a printer or printing process to the left of the company name "Teca-Print" in a bold, blue, sans-serif font.

Teca-Print AG  
Postfach  
Bohlstrasse 17  
CH-8240 Thayngen

Tel. +41 52 645 2000  
Fax +41 52 645 2102  
[info@teca-print.com](mailto:info@teca-print.com)  
[teca-print.com](http://teca-print.com)