

深圳市宇讯达电子有限公司

地址：深圳市龙华区五和大道牛角龙工业园A5栋
电话：0755-83460508/26975191/26976364
传真：0755-83460165/26976284
E-mail：info@yuxunda.com
网站：http://www.yuxunda.com
邮箱：518110

SHENZHEN YUXUNDA ELECTRONICS CO., LTD

Add: A5 Building, Niujiulong Industrial Park, Wuhe Avenue,
Longhua District, Shenzhen, Guangdong, China.
Tel: 0755-83460508/26975191/26976364
Fax: 0755-83460165/26976284
E-mail: info@yuxunda.com
Website: http://www.yuxunda.com
Code: 518110



深圳市宇讯达电子有限公司
SHENZHEN YUXUNDA ELECTRONICS CO., LTD

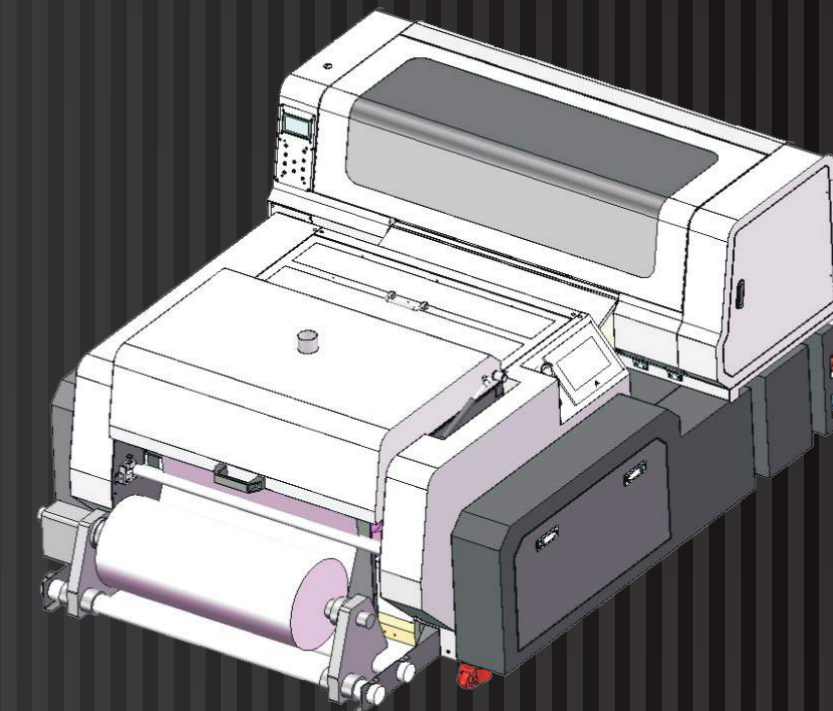



公司简介 COMPANY PROFILE

深圳市宇讯达电子有限公司坚持以人为本，拥有全国数码打印行业优秀的专业技术人才，研发团队拥有多年行业开发经验，成功打造多种系列数码印刷产品，在全国市场处于领先地位，积累了良好的客户口碑和品牌形象。同时宇讯达也在不断走向全球，为全球100多个国家和地区提供良好的产品和行业解决方案，成为行业进军全球的领头羊。

SHENZHEN YUXUNDA ELECTRONICS CO., LTD. adheres to the principle of people-oriented, has excellent professional and technical talents in the digital printing industry across the country, and the R&D team has many years of industry development experience, has successfully created a variety of series of digital printing products, and is in the leading position in the national market, and has accumulated good customer reputation and brand image. At the same time, Yuxunda is also constantly going global, providing good products and industry solutions for more than 100 countries and regions around the world, and becoming the leader of the industry in the world.



专注打印设备 Focus On Printing Equipment

目录 CONTENTS

- YXD-DTF Series (一体机)
- YXD-DTF Series (系列)
- YXD-DTF 耗材
- YXD-DTG/DTF Series (系列)
- YXD-DTG Series (系列)
- YXD-DTG 耗材

操作流程 OPERATION PROCESS

YXD-DTF Series (一体机)

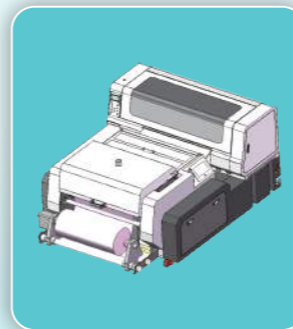
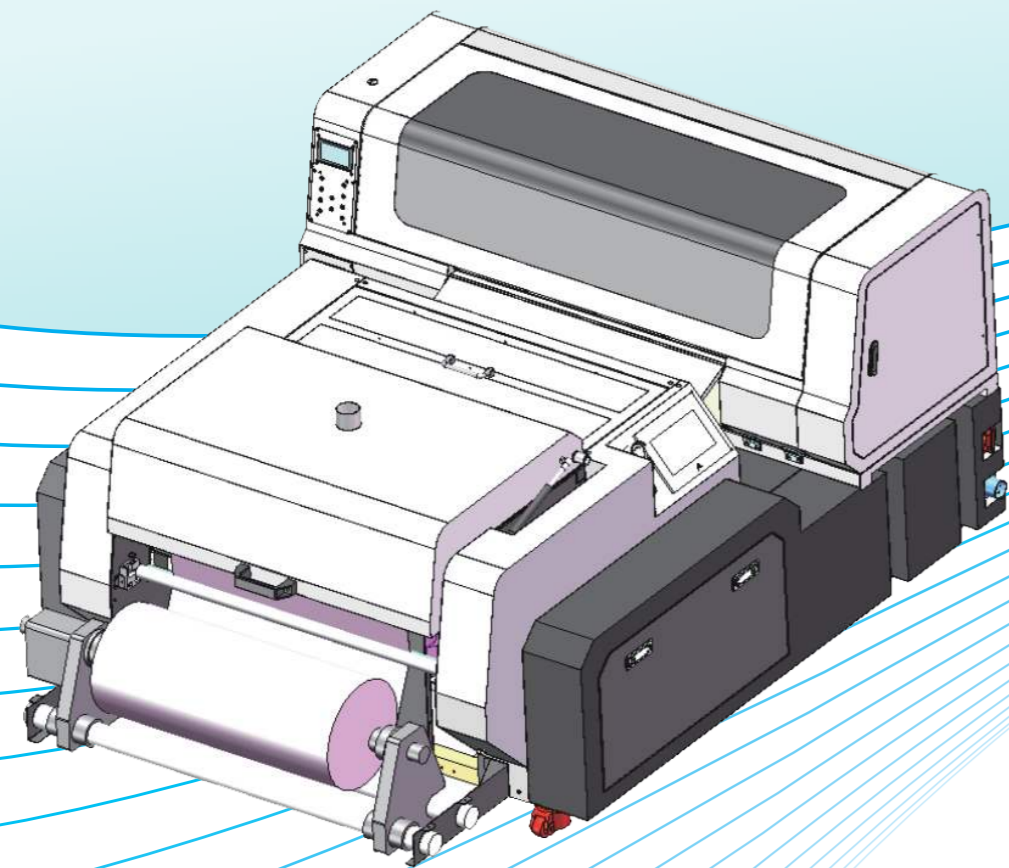

双头/四头打印机
Two-head/Four-head printer

耗材
Consumables



印刷膜
Printing film

压烫机
Press press



成品效果
Finished product effect

应用方案 APPLICATION SCHEME

适用介质：T恤，化纤，棉布，皮革，泳衣 卫衣，环保袋，抱枕，帽子，裤子，家纺布料。

Applicable medium: T-shirt, Polyester, Cotton, Leather, Swimwear, Sweatshirt, Suchion, Cap, Pants, Home, Texiiles.



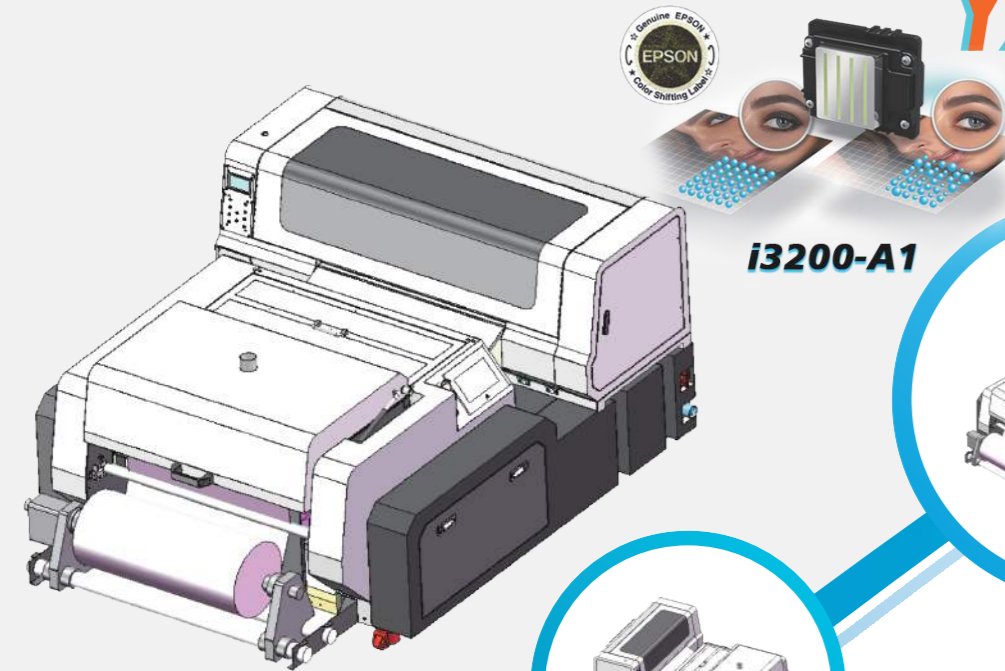

YXD-A600PRO MAX





i3200-A1

产品特点 PRODUCT FEATURES

 汉森板卡, 速度快, 稳定性好, 成本低, 占地面积小, 性价比高。
Honsen board, fast speed, good stability, low cost, small footprint, high cost performance.

 白墨搅拌加循环, 不沉淀, 保证打印流畅性;
Stirring and circulation of white ink, noprecipitation,smooth printing.

 操作界面: 全新的外观的设计, LED触摸屏, 操作简单 (AUTO) 屏幕开机动画可接客户LOGO定制, 可以在线远程升级软件。
Operation control panel:Brand new appearance design,LED touch screen,easy operation,logo custom,remotely upgrade software.

 烘干隧道: 新增加长式你2段烘干隧道, 能让材料能更充分受热, 使PET膜在不变用的情况下, 让图案呈现最完美状态。
Drying channel:Two more heating tube,completely heating,make printed film perfect.

 自动上粉功能: 智能化抖粉机, 自动撒粉 / 自动回粉, 真正做到无人值守
Automatic powder recycling: Intelligent powder spraying,automatic powder spraying/powder recycling spraying,no need man monitor the powder spraying.

 简单易用, 打印+撒粉+烘干, 一气呵成。
Simple and easy to use, printing, powder sparing and drying in 1.

应用行业 APPLICATION INDUSTRY

适用介质: T恤, 化纤, 棉布, 皮革, 泳衣 卫衣, 环保袋, 抱枕, 帽子, 家纺布料。

Applicable medium: T-shirt, Polyster, Cotton, Leather, Swimwear, Sweatshirt, Suchion, Cap, Home, Texiiles.



产品参数 APPLICATION FIELD SCHEME

名称(Name)	YXD-A600Pro Max (一体机)
型号(Model)	DTF-A600Pro Max
打印头(Printhead)	i3200-A1*2
颜色(Color)	C / M/ Y/ K + W / W / W / W
打印速度(Printing Speed)	8m ² /H,6Pass 6m ² /H,8Pass (1440/2160/2880dpi)
墨水(Ink)	颜料墨水(Pigment ink)
墨水系统(Ink System)	0.5升墨水瓶 & 白色墨水循环 & 墨水注入 (0.5L ink bottle & White ink circulation & Ink tiring)
最大宽度(Max Width)	600mm
Rip软件(Rip Software)	PP软件(Photoprint(PP))
色彩管理(Color Management)	ICC或密度曲线(ICC or density curve)
收放介质宽幅Printing width	0-600mm
上粉控制Powder spraying control	自动回粉,抖粉控制,撒粉控制,方向,量的控制 powder recycling spraying,The control of shaking,spraying,direction and power
加热烘干功能Heating function	静电棒,上烘干固化,冷风降温功能Electrostatic bar, heating tube drying,cooling function
材料传送方式Material transfer mode	网带传送,导带式Belt conveyer
收卷功能Wind and rewind function	自动感应收卷Automatic induction rewind
电压/功率Voltage/Power	电压: 220v Voltage:220V 功率: 4KW (能耗1KW-4KW) Power:4KW(rate power 1kw-4kw)
机器尺寸Machine size	机器尺寸:1930*1380*950mm 净重:300kg Machine size:1930*1380*950mm Net weight:300kg
包装尺寸Package size	包装尺寸:2050*1580*1100mm 毛重:350kg Package size:2050*1580*1100mm Gross weight:350kg

YXD-A460PROMAX

www.yuxunda.com

深圳市宇讯达电子有限公司
SHENZHEN YUXUNDA ELECTRONICS CO., LTD

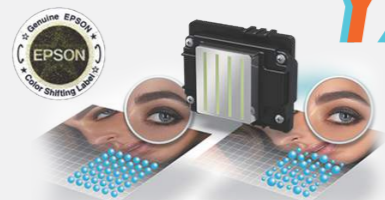



i3200-A1



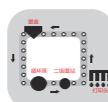

产品特点 PRODUCT FEATURES

 汉森板卡, 速度快, 稳定性好, 成本低, 占地面积小, 性价比高。
Honson board, fast speed, good stability, low cost, small footprint, high cost performance.

 白墨搅拌加循环, 不沉淀, 保证打印流畅性;
Stirring and circulation of white ink, noprecipitation, smooth printing.

 操作界面: 全新的外观的设计, LED触摸屏, 操作简单 (AUTO) 屏幕开机动画可接客户LOGO定制, 可以在线远程升级软件。
Operation control panel: Brand new appearance design, LED touch screen, easy operation, logo custom, remotely upgrade software.

 烘干隧道: 新增加长式你2段烘干隧道, 能让材料能更充分受热, 使PET膜在不变用的情况下, 让图案呈现最完美状态。
Drying channel: Two more heating tube, completely heating, make printed film perfect.

 自动上粉功能: 智能化抖粉机, 自动撒粉 / 自动回粉, 真正做到无人值守
Automatic powder recycling: Intelligent powder spraying, automatic powder spraying/powder recycling spraying, no need man monitor the powder spraying.

 简单易用, 打印+撒粉+烘干, 一气呵成。
Simple and easy to use, printing, powder sparing and drying in 1.

应用行业 APPLICATION INDUSTRY

适用介质: T恤, 化纤, 棉布, 皮革, 泳衣 卫衣, 环保袋, 抱枕, 帽子, 家纺布料。

Applicable medium: T-shirt, Polyester, Cotton, Leather, Swimwear, Sweatshirt, Suchion, Cap, Home, Textiles.



产品参数 APPLICATION FIELD SCHEME

名称(Name)	YXD-A460Pro Max (一体机)
型号(Model)	DTF-A460Pro Max
打印头(Printhead)	i3200-A1*2
颜色(Color)	C / M / Y / K + W / W / W / W
打印速度(Printing Speed)	8m ² /H, 6Pass 6m ² /H, 8Pass (1440/2160/2880dpi)
墨水(Ink)	颜料墨水(Pigment ink)
墨水系统(Ink System)	0.5升墨水瓶 & 白色墨水循环 & 墨水注入 (0.5L ink bottle & White ink circulation & Ink tiring)
最大宽度(Max Width)	400mm
Rip软件(Rip Software)	PP软件(Photoprint(PP))
色彩管理(Color Management)	ICC或密度曲线(ICC or density curve)
收放介质宽幅Printing width	0-450mm
上粉控制Powder spraying control	自动回粉, 抖粉控制, 撒粉控制, 方向, 量的控制 powder recycling spraying, The control of shaking, spraying, direction and power
加热烘干功能Heating function	静电棒, 上烘干固化, 冷风降温功能Electrostatic bar, heating tube drying, cooling function
材料传送方式Material transfer mode	网带传送, 导带式Belt conveyor
收卷功能Wind and rewind function	自动感应收卷Automatic induction rewind
电压/功率Voltage/Power	电压: 220v Voltage:220V 功率: 3.5KW (能耗1KW-3.5KW) Power:3.5KW(rate power 1kw-3.5kw)
机器尺寸Machine size	机器尺寸:1930*1140*950mm 净重:260kg Machine size:1930*1140*950mm Net weight:260kg
包装尺寸Package size	包装尺寸:2050*1200*1100mm 毛重:290kg Package size:2050*1200*1100mm Gross weight:290kg

YXD-A300PROMAX

www.yuxunda.com

深圳市宇讯达电子有限公司
SHENZHEN YUXUNDA ELECTRONICS CO., LTD

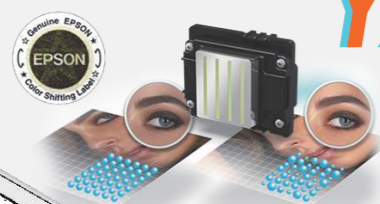
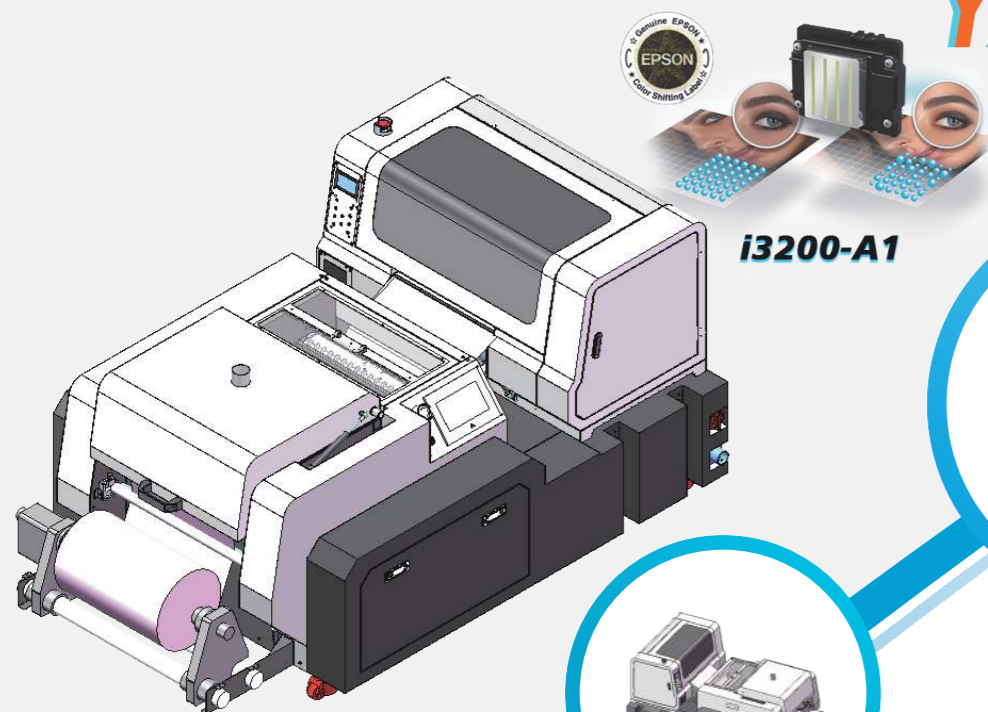

i3200-A1

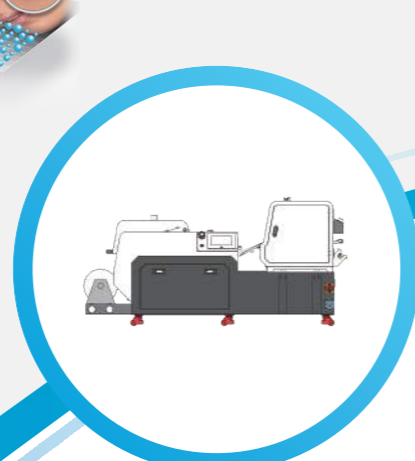

产品特点 PRODUCT FEATURES

 汉森板卡, 速度快, 稳定性好, 成本低, 占地面积小, 性价比高。
Honson board, fast speed, good stability, low cost, small footprint, high cost performance.

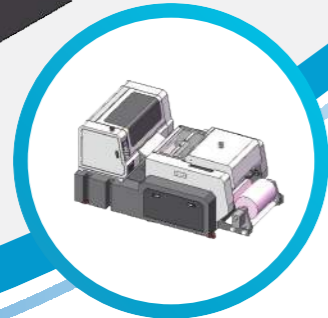

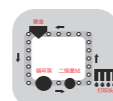
 白墨搅拌加循环, 不沉淀, 保证打印流畅性;
Stirring and circulation of white ink, noprecipitation,smooth printing.



操作界面: 全新的外观的设计, LED触摸屏, 操作简单 (AUTO) 屏幕开机动画可接客户LOGO定制, 可以在线远程升级软件。
Operation control panel:Brand new appearance design,LED touch screen,easy operation,logo custom,remotely upgrade software.



烘干隧道: 新增加长式你2段烘干隧道, 能让材料能更充分受热, 使PET膜在不变用的情况下, 让图案呈现最完美状态。
Drying channel:Two more heating tube,completely heating,make printed film perfect.



自动上粉功能: 智能化抖粉机, 自动撒粉 / 自动回粉, 真正做到无人值守
Automatic powder recycling:Intelligent powder spraying,automatic powder spraying/powder recycling spraying,no need man monitor the powder spraying.



简单易用, 打印+撒粉+烘干, 一气呵成。
Simple and easy to use, printing, powder sparing and drying in 1.

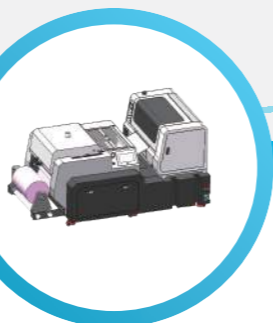

应用行业 APPLICATION INDUSTRY

适用介质: T恤, 化纤, 棉布, 皮革, 泳衣 卫衣, 环保袋, 抱枕, 帽子, 家纺布料。

Applicable medium: T-shirt, Polyster, Cotton, Leather, Swimwear, Sweatshirt, Suchion, Cap, Home, Texiiles.



产品参数 APPLICATION FIELD SCHEME

名称(Name)	YXD-A3000Pro Max (一体机)
型号(Model)	DTF-A300Pro Max
打印头(Printhead)	i3200-A1*2
颜色(Color)	C / M/ Y/ K + W / W / W / W
打印速度(Printing Speed)	8m ² /H,6Pass 6m ² /H,8Pass (1440/2160/2880dpi)
墨水(Ink)	颜料墨水(Pigment ink)
墨水系统(Ink System)	0.5升墨水瓶 & 白色墨水循环 & 墨水注入 (0.5L ink bottle & White ink circulation & Ink tiring)
最大宽度(Max Width)	300mm
Rip软件(Rip Software)	PP软件(Photoprint(PP))
色彩管理(Color Management)	ICC或密度曲线(ICC or density curve)
收放介质宽幅Printing width	0-300mm
上粉控制Powder spraying control	自动回粉,抖粉控制,撒粉控制,方向,量的控制 powder recycling spraying.The control of shaking,spraying,direction and power
加热烘干功能Heating function	静电棒,上烘干固化,冷风降温功能Electrostatic bar, heating tube drying,cooling function
材料传送方式Material transfer mode	网带传送,导带式Belt conveyor
收卷功能Wind and rewind function	自动感应收卷Automatic induction rewind
电压/功率Voltage/Power	电压: 220v Voltage:220V 功率: 3.5KW (能耗1KW-3.5KW) Power:3.5KW(rate power 1kw-3.5kw)
机器尺寸Machine size	机器尺寸:1930*1140*950mm 净重:260kg Machine size:1930*1140*950mm Net weight:260kg
包装尺寸Package size	包装尺寸:2050*1200*1100mm 毛重:290kg Package size:2050*1200*1100mm Gross weight:290kg

YXD-A460PLUS



F1080-A1



产品特点 PRODUCT FEATURES

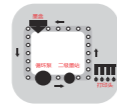

白墨搅拌加循环, 不沉淀, 保证打印流畅性;
Stirring and circulation of white ink, noprecipitation,smooth printing.



操作界面: 全新的外观的设计, LED触摸屏, 操作简单 (AUTO) 屏幕开机动画可接客户LOGO定制, 可以在线远程升级软件。
Operation control panel:Brand new appearance design,LED touch screen,easy operation,logo custom,remotely upgrade software.



烘干隧道: 新增加长式你2段烘干隧道, 能让材料能更充分受热, 使PET膜在不变用的情况下, 让图案呈现最完美状态。
Drying channel:Two more heating tube,completely heating,make printed film perfect.



自动上粉功能: 智能化抖粉机, 自动撒粉 / 自动回粉, 真正做到无人值守
Automatic powder recycling:Intelligent powder spraying,automatic powder spraying/powder recycling spraying,no need man monitor the powder spraying.



简单易用, 打印+撒粉+烘干,一气呵成。
Simple and easy to use, printing, powder sparing and drying in 1.

应用行业 APPLICATION INDUSTRY

适用介质: T恤, 化纤, 棉布, 皮革, 泳衣 卫衣, 环保袋, 抱枕, 帽子, 家纺布料。

Applicable medium: T-shirt, Polyster, Cotton, Leather, Swimwear, Sweatshirt, Suchion, Cap, Home, Texiiles.



产品参数 APPLICATION FIELD SCHEME

名称(Name)	YXD-A460Plus (一体机)
型号(Model)	DTF-A460Plus
打印头(Printhead)	F1080-A1(XP600)*2
颜色(Color)	C / M/ Y/ K / LM / LC + W / W / W / W / W / W
打印速度(Printing Speed)	4m ² /H,6Pass 3m ² /H,8Pass (1440/2160/2880dpi)
墨水(Ink)	颜料墨水(Pigment ink)
墨水系统(Ink System)	0.5升墨水瓶 & 白色墨水循环 & 墨水注入 (0.5L ink bottle & White ink circulation & Ink tiring)
最大宽度(Max Width)	400mm
Rip软件(Rip Software)	PP软件(Photoprint(PP))
色彩管理(Color Management)	ICC或密度曲线(ICC or density curve)
收放介质宽幅Printing width	0-450mm
上粉控制Powder spraying control	自动回粉,抖粉控制,撒粉控制,方向,量的控制 powder recycling spraying.The control of shaking,spraying,direction and power
加热烘干功能Heating function	静电棒,上烘干固化,冷风降温功能Electrostatic bar, heating tube drying,cooling function
材料传送方式Material transfer mode	网带传送,导带式Belt conveyor
收卷功能Wind and rewind function	自动感应收卷Automatic induction rewind
电压/功率Voltage/Power	电压: 220v Voltage:220V 功率: 3.5KW (能耗1KW-3.5KW) Power:3.5KW(rate power 1kw-3.5kw)
机器尺寸Machine size	机器尺寸:1930*1140*950mm 净重:260kg Machine size:1930*1140*950mm Net weight:260kg
包装尺寸Package size	包装尺寸:2050*1200*1100mm 毛重:290kg Package size:2050*1200*1100mm Gross weight:290kg

YXD-A300PLUS

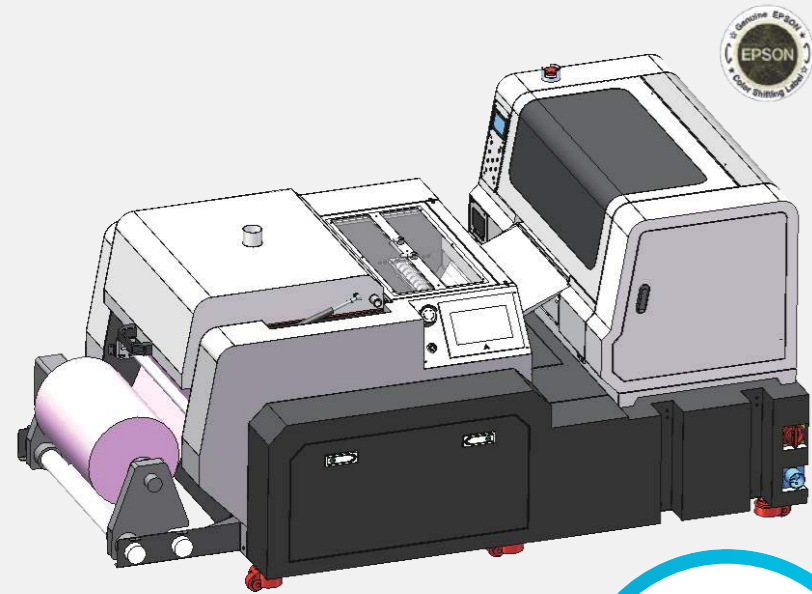

F1080-A1

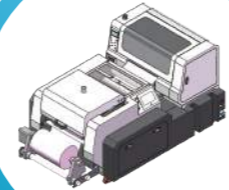
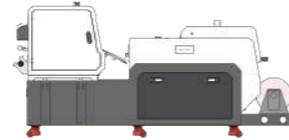

产品特点 PRODUCT FEATURES

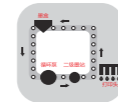
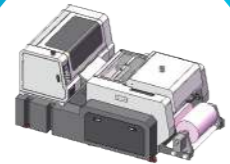

白墨搅拌加循环，不沉淀，保证打印流畅性。
Stirring and circulation of white ink, noprecipitation,smooth printing.



操作界面：全新的外观的设计，LED触摸屏，操作简单（AUTO）屏幕开机动画可接客户LOGO定制，可以在线远程升级软件。
Operation control panel:Brand new appearance design,LED touch screen,easy operation,logo custom,remotely upgrade software.



烘干隧道：新增加长式你2段烘干隧道，能让材料能更充分受热，使PET膜在不变用的情况下，让图案呈现最完美状态。
Drying channel:Two more heating tube,completely heating,make printed film perfect.



自动上粉功能：智能化抖粉机，自动撒粉 / 自动回粉，真正做到无人值守
Automatic powder recycling:Intelligent powder spraying,automatic powder spraying/powder recycling spraying,no need man monitor the powder spraying.



简单易用，打印+撒粉+烘干，一气呵成。
Simple and easy to use, printing, powder sparing and drying in 1.

应用行业 APPLICATION INDUSTRY

适用介质：T恤，化纤，棉布，皮革，泳衣 卫衣，环保袋，抱枕，帽子，家纺布料。

Applicable medium: T-shirt, Polyster, Cotton, Leather, Swimwear, Sweatshirt, Suchion, Cap, Home, Texiiles.



产品参数 APPLICATION FIELD SCHEME

名称(Name)	YXD-A300Plus (一体机)
型号(Model)	DTF-A300Plus
打印头(Printhead)	F1080-A1(XP600)*2
颜色(Color)	C / M/ Y/ K / LM / LC + W / W / W / W / W / W
打印速度(Printing Speed)	4m ² /H,6Pass 3m ² /H,8Pass (1440/2160/2880dpi)
墨水(Ink)	颜料墨水(Pigment ink)
墨水系统(Ink System)	0.5升墨水瓶 & 白色墨水循环 & 墨水注入 (0.5L ink bottle & White ink circulation & Ink tiring)
最大宽度(Max Width)	300mm
Rip软件(Rip Software)	PP软件(Photoprint(PP))
色彩管理(Color Management)	ICC或密度曲线(ICC or density curve)
收放介质宽幅Printing width	0-300mm
上粉控制Powder spraying control	自动回粉,抖粉控制,撒粉控制,方向,量的控制 powder recycling spraying.The control of shaking,spraying,direction and power
加热烘干功能Heating function	静电棒,上烘干固化,冷风降温功能Electrostatic bar, heating tube drying,cooling function
材料传送方式Material transfer mode	网带传送,导带式Belt conveyor
收卷功能Wind and rewind function	自动感应收卷Automatic induction rewind
电压/功率Voltage/Power	电压: 220v Voltage:220V 功率: 3.5KW (能耗1KW-3.5KW) Power:3.5KW(rate power 1kw-3.5kw)
机器尺寸Machine size	机器尺寸:1930*1140*950mm 净重:260kg Machine size:1930*1140*950mm Net weight:260kg
包装尺寸Package size	包装尺寸:2050*1200*1100mm 毛重:290kg Package size:2050*1200*1100mm Gross weight:290kg

操作流程 OPERATION PROCESS

YXD-DTF Series (系列)

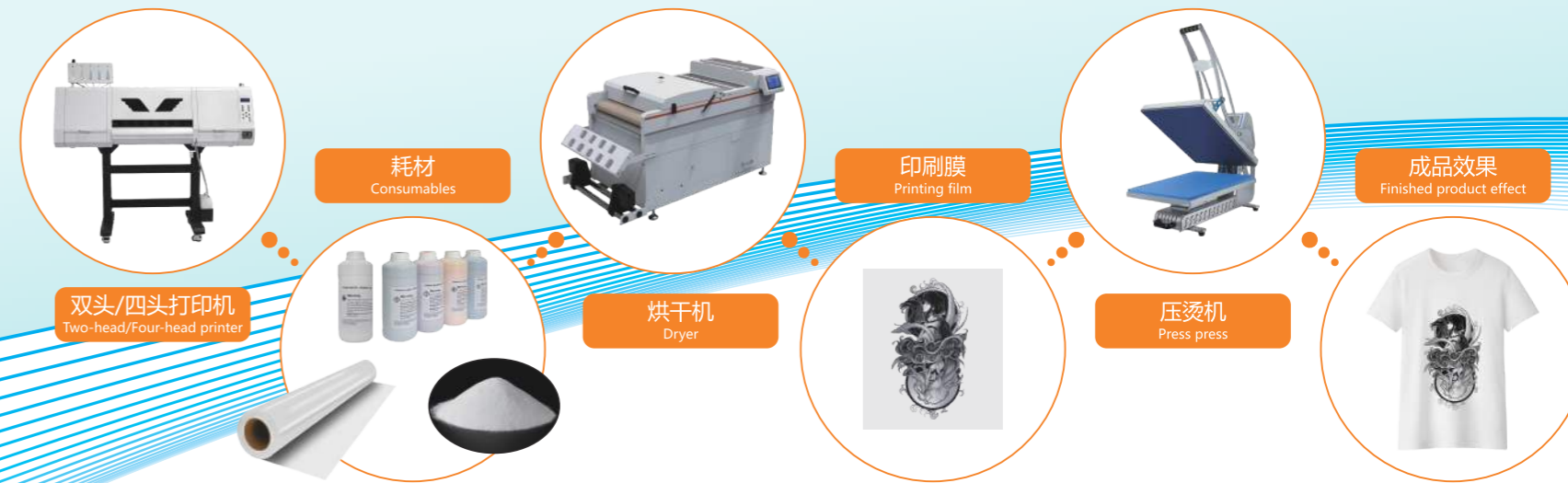
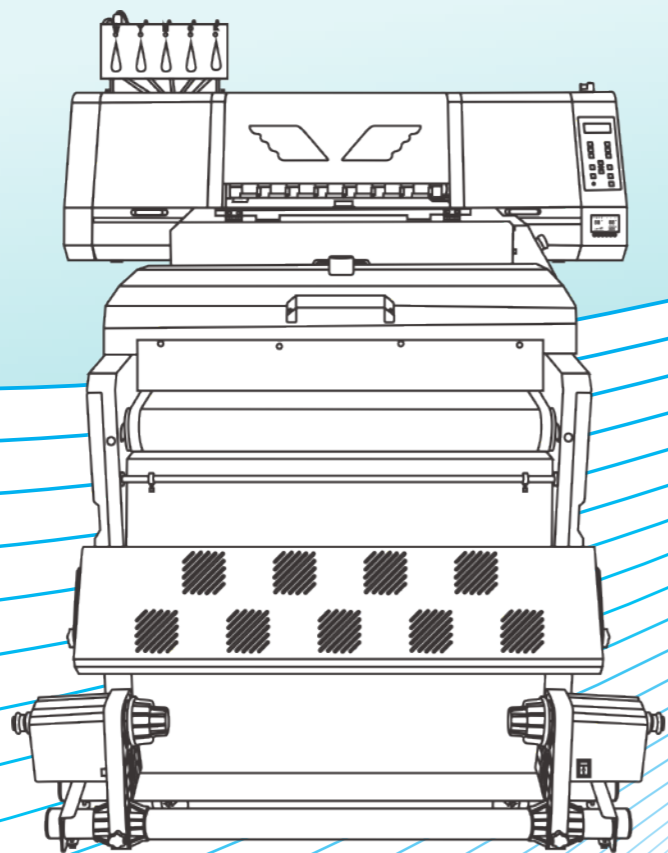

应用方案 APPLICATION SCHEME

适用介质：T恤，化纤，棉布，皮革，泳衣 卫衣，环保袋，抱枕，帽子，裤子，家纺布料。

Applicable medium: T-shirt, Polyester, Cotton, Leather, Swimwear, Sweatshirt, Suchion, Cap, Pants, Home, Texiiles.



YXD-600PRO MAX

www.yuxunda.com

深圳市宇讯达电子有限公司
SHENZHEN YUXUNDA ELECTRONICS CO., LTD



产品细节 PRODUCT DETAILS



Epson (I3200-A1) original print head



Main board (Hoson main board)



Machine control panel/heating/suction



Waste ink alarm system

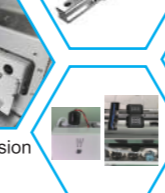

Anti collision system

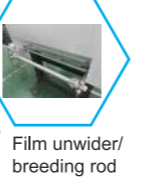

Film unwider/breeding rod

Automatic white ink stirring/white ink circulation system/automatic cleaning unit

产品特点 PRODUCT FEATURES

- 1. 汉森高精度、高速度稳定网口板卡,打印细腻,喷画鲜艳。
Hoson high-precision, high-speed and stable network port board card, delicate printing, bright spray painting.
- 2. 白墨搅拌加循环,不沉淀,保证打印流畅性。
White ink stirring and circulation no precipitation to ensure the smoothness of printing.
- 3. 个性化定制,白彩同出, 适用各种颜色、各种布料服装个性印花,增强市场竞争力。
white and color print at the same time, Bright colors,suitable for a variety of fabrics, clothing printing, personalized customization.
- 4. 抖粉机采用自动感应收卷功能省时、省力、省人工。
The powder Shake machine adopts automatic induction collecting function, saving time, saving cost.
- 5. 废粉回收技术避免浪费节约成本。
Waste powder recycling technology to avoid waste and save costs.
- 6. 简单易用, 打印+撒粉+烘干,一气呵成。
Simple and easy to use, printing powder drying.

产品参数

APPLICATION FIELD SCHEME

名称(Name)	60cm卷对卷dtf打印机(60cm roll to roll dtf printer)
型号(Model)	YXD-DTF-600Pro Max
打印头(Printhead)	i3200 A1*2
颜色(Color)	C / M/ Y/ K + W / W/ W / W
墨水(Ink)	颜料墨水(Pigment ink)
打印速度(Printing Speed)	10m ² /H,6Pass 8m ² /H,8Pass
打印精度(Printing resolution)	1440/2160/2880dpi
墨水系统(Ink System)	1.5升墨水瓶 & 白色墨水循环 & 墨水注入 (1.5L ink bottle & White ink circulation & Ink stirring)

最大宽度(Max Width)	600mm
Rip软件(Rip Software)	PP软件(Photoprint(PP))
色彩管理(Color Management)	ICC或密度曲线(ICC or density curve)
电压(Voltage)	220v/110v 50Hz/60Hz
打印机尺寸(Printer Size)	1755mm×700mm×1650mm
包装尺寸(Package Size)	1850mm×760mm×750mm
净重(Net Weight)	150KG
毛重(Gross Weight)	180KG

YXD-600

www.yuxunda.com

深圳市宇讯达电子有限公司
SHENZHEN YUXUNDA ELECTRONICS CO., LTD

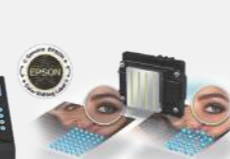

产品细节 PRODUCT DETAILS

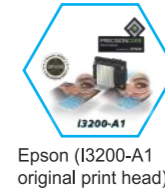

Epson (I3200-A1) original print head



Main board (main board)



Waste ink alarm system

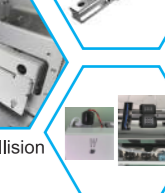

Anti collision system



Film unwider/breeding rod

Automatic white ink stirring/white ink circulation system/automatic cleaning unit

产品特点 PRODUCT FEATURES

- 1. 高精度、高速度稳定网口板卡,打印细腻,喷画鲜艳。
high-precision, high-speed and stable network port board card, delicate printing, bright spray painting.
- 2. 白墨搅拌加循环,不沉淀,保证打印流畅性。
White ink stirring and circulation no precipitation to ensure the smoothness of printing.
- 3. 个性化定制,白彩同出, 适用各种颜色、各种布料服装个性印花,增强市场竞争力。
white and color print at the same time, Bright colors,suitable for a variety of fabrics, clothing printing, personalized customization.
- 4. 抖粉机采用自动感应收卷功能省时、省力、省人工。
The powder Shake machine adopts automatic induction collecting function, saving time, saving cost.
- 5. 废粉回收技术避免浪费节约成本。
Waste powder recycling technology to avoid waste and save costs.
- 6. 简单易用, 打印+撒粉+烘干,一气呵成。
Simple and easy to use, printing powder drying.

产品参数

APPLICATION FIELD SCHEME

名称(Name)	60cm卷对卷dtf打印机(60cm roll to roll dtf printer)
型号(Model)	YXD-DTF-600
打印头(Printhead)	i3200 A1*2
颜色(Color)	C / M/ Y/ K + W / W/ W / W
墨水(Ink)	颜料墨水(Pigment ink)
打印速度(Printing Speed)	10m ² /H,6Pass 8m ² /H,8Pass
打印精度(Printing resolution)	1440/2160/2880dpi
墨水系统(Ink System)	1.5升墨水瓶 & 白色墨水循环 & 墨水注入 (1.5L ink bottle & White ink circulation & Ink stirring)

最大宽度(Max Width)	600mm
Rip软件(Rip Software)	PP软件(Photoprint(PP))
色彩管理(Color Management)	ICC或密度曲线(ICC or density curve)
电压(Voltage)	220v/110v 50Hz/60Hz
打印机尺寸(Printer Size)	1755mm×700mm×1650mm
包装尺寸(Package Size)	1850mm×760mm×750mm
净重(Net Weight)	140KG
毛重(Gross Weight)	170KG

YXD-400PRO MAX

www.yuxunda.com

深圳市宇讯达电子有限公司
SHENZHEN YUXUNDA ELECTRONICS CO., LTD



产品细节 PRODUCT DETAILS



Epson (I3200-A1) original print head



Main board (Hoson main board)



Machine control panel/heating/suction



Waste ink alarm system

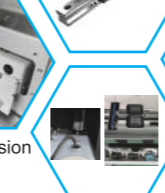

Anti collision system

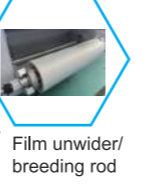

Film unwider/breeding rod

Automatic white ink stirring/white ink circulation system/automatic cleaning unit

产品特点 PRODUCT FEATURES

- 1. 汉森高精度、高速度稳定网口板卡,打印细腻,喷画鲜艳。
Hoson high-precision, high-speed and stable network port board card, delicate printing, bright spray painting.
- 2. 白墨搅拌加循环,不沉淀,保证打印流畅性。
White ink stirring and circulation no precipitation to ensure the smoothness of printing.
- 3. 个性化定制,白彩同出, 适用各种颜色、各种布料服装个性印花,增强市场竞争力。
white and color print at the same time, Bright colors,suitable for a variety of fabrics, clothing printing, personalized customization.
- 4. 抖粉机采用自动感应收卷功能省时、省力、省人工。
The powder Shake machine adopts automatic induction collecting function, saving time, saving cost.
- 5. 废粉回收技术避免浪费节约成本。
Waste powder recycling technology to avoid waste and save costs.
- 6. 简单易用, 打印+撒粉+烘干,一气呵成。
Simple and easy to use, printing powder drying.

产品参数

APPLICATION FIELD SCHEME

名称(Name)	40cm卷对卷dtf打印机(40cm roll to roll dtf printer)
型号(Model)	YXD-DTF-400Pro Max
打印头(Printhead)	i3200 A1*2
颜色(Color)	C / M/ Y/ K + W / W/ W / W
墨水(Ink)	颜料墨水(Pigment ink)
打印速度(Printing Speed)	8m ² /H,6Pass 6m ² /H,8Pass
打印精度(Printing resolution)	1440/2160/2880dpi
墨水系统(Ink System)	500毫升墨水瓶 & 白色墨水循环 & 墨水注入 (500ml ink bottle & White ink circulation & Ink stirring)

最大宽度(Max Width)	400mm
Rip软件(Rip Software)	PP软件(Photoprint(PP))
色彩管理(Color Management)	ICC或密度曲线(ICC or density curve)
电压(Voltage)	220v/110v 50Hz/60Hz
打印机尺寸(Printer Size)	1140mm×640mm×1140mm
包装尺寸(Package Size)	1100mm×760mm×730mm
净重(Net Weight)	85KG
毛重(Gross Weight)	105KG

YXD-300PRO MAX

www.yuxunda.com

深圳市宇讯达电子有限公司
SHENZHEN YUXUNDA ELECTRONICS CO., LTD



产品细节 PRODUCT DETAILS



Epson (I3200-A1) original print head



Main board (Hoson main board)



Machine control panel/heating/suction



Waste ink alarm system

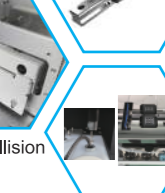

Anti collision system

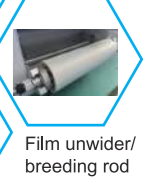

Film unwider/breeding rod

Automatic white ink stirring/white ink circulation system/automatic cleaning unit

产品特点 PRODUCT FEATURES

- 1. 汉森高精度、高速度稳定网口板卡,打印细腻,喷画鲜艳。
Hoson high-precision, high-speed and stable network port board card, delicate printing, bright spray painting.
- 2. 白墨搅拌加循环,不沉淀,保证打印流畅性。
White ink stirring and circulation no precipitation to ensure the smoothness of printing.
- 3. 个性化定制,白彩同出, 适用各种颜色、各种布料服装个性印花,增强市场竞争力。
white and color print at the same time, Bright colors,suitable for a variety of fabrics, clothing printing, personalized customization.
- 4. 抖粉机采用自动感应收卷功能省时、省力、省人工。
The powder Shake machine adopts automatic induction collecting function, saving time, saving cost.
- 5. 废粉回收技术避免浪费节约成本。
Waste powder recycling technology to avoid waste and save costs.
- 6. 简单易用, 打印+撒粉+烘干,一气呵成。
Simple and easy to use, printing powder drying.

产品参数

APPLICATION FIELD SCHEME

名称(Name)	30cm卷对卷dtf打印机(30cm roll to roll dtf printer)
型号(Model)	YXD-DTF-300Pro Max
打印头(Printhead)	i3200-A1*2
颜色(Color)	C / M/ Y/ K /+ W / W / W / W
墨水(Ink)	颜料墨水(Pigment ink)
打印速度(Printing Speed)	8m ² /H,6Pass 6m ² /H,8Pass
打印精度(Printing resolution)	1440/2160/2880dpi
墨水系统(Ink System)	500毫升墨水瓶 & 白色墨水循环 & 墨水注入 (500ml ink bottle & White ink circulation & Ink stirring)

最大宽度(Max Width)	300mm
Rip软件(Rip Software)	PP软件(Photoprint(PP))
色彩管理(Color Management)	ICC或密度曲线(ICC or density curve)
电压(Voltage)	220v/110v 50Hz/60Hz
打印机尺寸(Printer Size)	980mm×540mm×1140mm
包装尺寸(Package Size)	1100mm×760mm×730mm
净重(Net Weight)	70KG
毛重(Gross Weight)	90KG

YXD-400PLUS

www.yuxunda.com

深圳市宇讯达电子有限公司
SHENZHEN YUXUNDA ELECTRONICS CO., LTD



产品细节 PRODUCT DETAILS



Epson (F1080-A1 original print head)



Main board (Hoson main board)



Machine control panel/heating/suction



Waste ink alarm system



Anti collision system



THK guide



Film unwinder/breeding rod

Automatic white ink stirring/white ink circulation system/automatic cleaning unit

产品特点 PRODUCT FEATURES

- 1. 汉森高精度、高速度稳定网口板卡,打印细腻,喷画鲜艳。
Hoson high-precision, high-speed and stable network port board card, delicate printing, bright spray painting.
- 2. 白墨搅拌加循环,不沉淀,保证打印流畅性。
White ink stirring and circulation no precipitation to ensure the smoothness of printing.
- 3. 个性化定制,白彩同出, 适用各种颜色、各种布料服装个性印花,增强市场竞争力。
white and color print at the same time, Bright colors,suitable for a variety of fabrics, clothing printing, personalized customization.
- 4. 抖粉机采用自动感应收卷功能省时、省力、省人工。
The powder Shake machine adopts automatic induction collecting function, saving time, saving cost.
- 5. 废粉回收技术避免浪费节约成本。
Waste powder recycling technology to avoid waste and save costs.
- 6. 简单易用, 打印+撒粉+烘干,一气呵成。
Simple and easy to use, printing powder drying.

产品参数

APPLICATION FIELD SCHEME

名称(Name)	40cm卷对卷dtf打印机(40cm roll to roll dtf printer)
型号(Model)	YXD-DTF-400Plus
打印头(Printhead)	F1080-A1*2(XP600)
颜色(Color)	C / M / Y / K / LM / LC + W / W / W / W / W / W
墨水(Ink)	颜料墨水(Pigment ink)
打印速度(Printing Speed)	4m ² /H,6Pass 3m ² /H,8Pass
打印精度(Printing resolution)	1440/2160/2880dpi
墨水系统(Ink System)	500毫升墨水瓶 & 白色墨水循环 & 墨水注入 (500ml ink bottle & White ink circulation & Ink stirring)

最大宽度(Max Width)	400mm
Rip软件(Rip Software)	PP软件(Photoprint(PP))
色彩管理(Color Management)	ICC或密度曲线(ICC or density curve)
电压(Voltage)	220v/110v 50Hz/60Hz
打印机尺寸(Printer Size)	1140mm×640mm×1140mm
包装尺寸(Package Size)	1100mm×760mm×730mm
净重(Net Weight)	85KG
毛重(Gross Weight)	105KG

YXD-300PLUS

www.yuxunda.com

深圳市宇讯达电子有限公司
SHENZHEN YUXUNDA ELECTRONICS CO., LTD



产品细节 PRODUCT DETAILS



Epson (F1080-A1 original print head)



Main board (Hoson main board)



Machine control panel/heating/suction



Waste ink alarm system



Anti collision system



THK guide



Film unwinder/breeding rod

Automatic white ink stirring/white ink circulation system/automatic cleaning unit

产品特点 PRODUCT FEATURES

- 1. 汉森高精度、高速度稳定网口板卡,打印细腻,喷画鲜艳。
Hoson high-precision, high-speed and stable network port board card, delicate printing, bright spray painting.
- 2. 白墨搅拌加循环,不沉淀,保证打印流畅性。
White ink stirring and circulation no precipitation to ensure the smoothness of printing.
- 3. 个性化定制,白彩同出, 适用各种颜色、各种布料服装个性印花,增强市场竞争力。
white and color print at the same time, Bright colors,suitable for a variety of fabrics, clothing printing, personalized customization.
- 4. 抖粉机采用自动感应收卷功能省时、省力、省人工。
The powder Shake machine adopts automatic induction collecting function, saving time, saving cost.
- 5. 废粉回收技术避免浪费节约成本。
Waste powder recycling technology to avoid waste and save costs.
- 6. 简单易用, 打印+撒粉+烘干,一气呵成。
Simple and easy to use, printing powder drying.

产品参数

APPLICATION FIELD SCHEME

名称(Name)	30cm卷对卷dtf打印机(30cm roll to roll dtf printer)
型号(Model)	YXD-DTF-300Plus
打印头(Printhead)	F1080-A1*2(XP600)
颜色(Color)	C / M / Y / K / LM / LC + W / W / W / W / W / W
墨水(Ink)	颜料墨水(Pigment ink)
打印速度(Printing Speed)	4m ² /H,6Pass 3m ² /H,8Pass
打印精度(Printing resolution)	1440/2160/2880dpi
墨水系统(Ink System)	500毫升墨水瓶 & 白色墨水循环 & 墨水注入 (500ml ink bottle & White ink circulation & Ink stirring)

最大宽度(Max Width)	300mm
Rip软件(Rip Software)	PP软件(Photoprint(PP))
色彩管理(Color Management)	ICC或密度曲线(ICC or density curve)
电压(Voltage)	220v/110v 50Hz/60Hz
打印机尺寸(Printer Size)	980mm×540mm×1140mm
包装尺寸(Package Size)	1100mm×760mm×730mm
净重(Net Weight)	70KG
毛重(Gross Weight)	90KG

YXD-H450



产品特点

PRODUCT FEATURES

■ 操作界面：全新的外观的设计，LED触摸屏，操作简单（AUTO）屏幕开机动画可接客户LOGO定制，可以在线远程升级软件。
Operation control panel: new appearance design, LED touch screen, easy operation, logo custom, remotely upgrade software.

■ 烘干隧道：新增加长式你2段烘干隧道，能让材料能更充分受热，使PET膜在不变用的情况下，让图案呈现最完美状态。
Drying channel: Lengthen heating tube, completely heating, make printed film perfect.

■ 本机采用自动感应卷绕功能，省时、省力、省力。
The powder shaking machine adopts automatic induction winding function, which saves time and labor.

■ 废粉回收技术，避免浪费和节约成本。
Waste powder recycling technology, avoiding waste and saving cost.

■ 简单易用，打印+撒粉+烘干，一气呵成。
Simple and easy to use, printing, powder sparing and drying in 1.

产品参数

APPLICATION FIELD SCHEME

名称型号Model Name	DTF抖粉机H450 Powder Spraying Machine H450
收放介质宽幅Printing width	0-450mm
上粉控制Powder spraying control	抖粉控制，撒粉控制，方向，量的控制The control of shaking, spraying, direction and power
加热烘干功能Heating function	静电棒，上烘干固化，冷风降温功能Electrostatic bar, heating tube drying, cooling function
材料传送方式Material transfer mode	网带传送，导带式Belt conveyor
收卷功能Wind and rewind function	自动感应收卷Automatic induction rewind
电压/功率Voltage/Power	电压: 220v Voltage:220V 功率: 3KW (能耗1KW-3KW) Power:3KW(rate power 1kw-3kw)
机器尺寸Machine size	机器尺寸:1350*650*895mm 净重:180kg Machine size:1350*650*895mm Net weight:180kg
包装尺寸Package size	包装尺寸:1450*850*1050mm 毛重:250kg Package size:1450*850*1050mm Gross weight:250kg

YXD-H650



产品特点

PRODUCT FEATURES

■ 操作界面：全新的外观的设计，LED触摸屏，操作简单（AUTO）屏幕开机动画可接客户LOGO定制，可以在线远程升级软件。
Operation control panel: new appearance design, LED touch screen, easy operation, logo custom, remotely upgrade software.

■ 烘干隧道：新增加长式你2段烘干隧道，能让材料能更充分受热，使PET膜在不变用的情况下，让图案呈现最完美状态。
Drying channel: Lengthen heating tube, completely heating, make printed film perfect.

■ 本机采用自动感应卷绕功能，省时、省力、省力。
The powder shaking machine adopts automatic induction winding function, which saves time and labor.

■ 废粉回收技术，避免浪费和节约成本。
Waste powder recycling technology, avoiding waste and saving cost.

■ 简单易用，打印+撒粉+烘干，一气呵成。
Simple and easy to use, printing, powder sparing and drying in 1.

产品参数

APPLICATION FIELD SCHEME

名称型号Model Name	DTF抖粉机H650 Powder Spraying Machine H650
收放介质宽幅Printing width	0-600mm
上粉控制Powder spraying control	抖粉控制，撒粉控制，方向，量的控制The control of shaking, spraying, direction and power
加热烘干功能Heating function	静电棒，上烘干固化，冷风降温功能Electrostatic bar, heating tube drying, cooling function
材料传送方式Material transfer mode	网带传送，导带式Belt conveyor
收卷功能Wind and rewind function	自动感应收卷Automatic induction rewind
电压/功率Voltage/Power	电压: 220v Voltage:220V 功率: 5KW (能耗3.5KW-5KW) Power:5KW(rate power 3.5kw-5kw)
机器尺寸Machine size	机器尺寸:1953*1002*1080mm 净重:240kg Machine size:1953*1002*1080mm Net weight:240kg
包装尺寸Package size	包装尺寸:1900*1070*1213mm 毛重:290kg Package size:1900*1070*1213mm Gross weight:290kg

YXD-Z650

www.yuxunda.com

深圳市宇讯达电子有限公司
SHENZHEN YUXUNDA ELECTRONICS CO., LTD

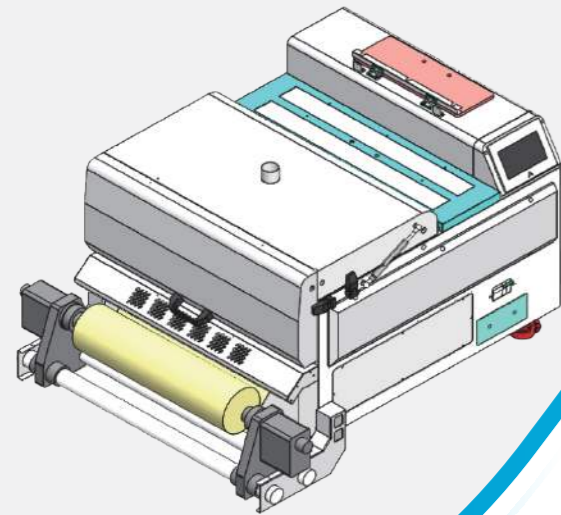

产品特点

PRODUCT FEATURES

■ 操作界面: 全新的外观的设计, LED触摸屏, 操作简单 (AUTO) 屏幕开机动画可接客户LOGO定制, 可以在线远程升级软件。
Operation control panel: new appearance design, LED touch screen, easy operation, logo custom, remotely upgrade software.

■ 烘干隧道: 新增加长式你2段烘干隧道, 能让材料能更充分受热, 使PET膜在不变用的情况下, 让图案呈现最完美状态。
Drying channel: Lengthen heating tube, completely heating, make printed film perfect.

■ 本机采用自动感应卷绕功能, 省时、省力、省力。
The powder shaking machine adopts automatic induction winding function, which saves time and labor.

■ 废粉回收技术, 避免浪费和节约成本。
Waste powder recycling technology, avoiding waste and saving cost.

■ 简单易用, 打印+撒粉+烘干, 一气呵成。
Simple and easy to use, printing, powder sparing and drying in 1.

产品参数

APPLICATION FIELD SCHEME

名称型号Model Name	DTF抖粉机Z650 Powder Spraying Machine Z650
收放介质宽幅Printing width	0-600mm
上粉控制Powder spraying control	抖粉控制, 撒粉控制, 方向, 量的控制The control of shaking, spraying, direction and power
加热烘干功能Heating function	静电棒, 上烘干固化, 冷风降温功能Electrostatic bar, heating tube drying, cooling function
材料传送方式Material transfer mode	网带传送, 导带式Belt conveyor
收卷功能Wind and rewind function	自动感应收卷Automatic induction rewind
电压/功率Voltage/Power	电压: 220v Voltage:220V 功率: 5KW (能耗1KW-5KW) Power:5KW(rate power 1kw-5kw)
机器尺寸Machine size	机器尺寸:1650*950*950mm 净重:200kg Machine size:1650*950*950mm Net weight:200kg
包装尺寸Package size	包装尺寸:1850*1100*1100mm 毛重:240kg Package size:1850*1100*1100mm Gross weight:240kg

YXD-H1300

www.yuxunda.com

深圳市宇讯达电子有限公司
SHENZHEN YUXUNDA ELECTRONICS CO., LTD



产品特点

PRODUCT FEATURES

■ 操作界面: 全新的外观的设计, LED触摸屏, 操作简单 (AUTO) 屏幕开机动画可接客户LOGO定制, 可以在线远程升级软件。
Operation control panel: new appearance design, LED touch screen, easy operation, logo custom, remotely upgrade software.

■ 烘干隧道: 新增加长式你2段烘干隧道, 能让材料能更充分受热, 使PET膜在不变用的情况下, 让图案呈现最完美状态。
Drying channel: Lengthen heating tube, completely heating, make printed film perfect.

■ 本机采用自动感应卷绕功能, 省时、省力、省力。
The powder shaking machine adopts automatic induction winding function, which saves time and labor.

■ 废粉回收技术, 避免浪费和节约成本。
Waste powder recycling technology, avoiding waste and saving cost.

■ 简单易用, 打印+撒粉+烘干, 一气呵成。
Simple and easy to use, printing, powder sparing and drying in 1.

产品参数

APPLICATION FIELD SCHEME

名称型号Model Name	DTF抖粉机H1300 Powder Spraying Machine H1300
收放介质宽幅Printing width	0-1300mm
上粉控制Powder spraying control	抖粉控制, 撒粉控制, 方向, 量的控制The control of shaking, spraying, direction and power
加热烘干功能Heating function	静电棒, 上烘干固化, 冷风降温功能Electrostatic bar, heating tube drying, cooling function
材料传送方式Material transfer mode	网带传送, 导带式Belt conveyor
收卷功能Wind and rewind function	自动感应收卷Automatic induction rewind
电压/功率Voltage/Power	电压: 220v Voltage:220V 功率: 10.2KW (能耗8KW-10.2KW) Power:10.2KW(rate power 8kw-10.2kw)
机器尺寸Machine size	机器尺寸:2840*1780*1100mm 净重:580kg Machine size:2840*1780*1100mm Net weight:580kg
包装尺寸Package size	包装尺寸:2850*1880*1236mm 毛重:620kg Package size:2850*1880*1236mm Gross weight:620kg

YXD-D650

www.yuxunda.com

深圳市宇讯达电子有限公司
SHENZHEN YUXUNDA ELECTRONICS CO., LTD

产品特点 PRODUCT FEATURES



■ 操作界面：全新的外观的设计，LED触摸屏，操作简单（AUTO）屏幕开机动画可接客户LOGO定制，可以在线远程升级软件。
Operation control panel: new appearance design, LED touch screen, easy operation, logo custom, remotely upgrade software.

■ 烘干隧道：新增加长式你2段烘干隧道，能让材料能更充分受热，使PET膜在不变用的情况下，让图案呈现最完美状态。
Drying channel: Lengthen heating tube, completely heating, make printed film perfect.

■ 本机采用自动感应卷绕功能，省时、省力、省力。
The powder shaking machine adopts automatic induction winding function, which saves time and labor.

■ 废粉回收技术，避免浪费和节约成本。
Waste powder recycling technology, avoiding waste and saving cost.

■ 简单易用，打印+撒粉+烘干，一气呵成。
Simple and easy to use, printing, powder sparing and drying in 1.

产品参数

APPLICATION FIELD SCHEME

名称型号Model Name	DTF抖粉机D650 Powder Spraying Machine D650
收放介质宽幅Printing width	0-600mm
上粉控制Powder spraying control	抖粉控制，撒粉控制，方向，量的控制The control of shaking, spraying, direction and power
加热烘干功能Heating function	静电棒，上烘干固化，冷风降温功能Electrostatic bar, heating tube drying, cooling function
材料传送方式Material transfer mode	网带传送，导带式Belt conveyor
收卷功能Wind and rewind function	自动感应收卷Automatic induction rewind
电压/功率Voltage/Power	电压: 220v Voltage:220V 功率: 4.4KW (能耗1.5KW-4.4KW) Power:4.4KW(rate power 1.5kw-4.4kw)
机器尺寸Machine size	机器尺寸:2028*1002*1171mm 净重:180kg Machine size:2028*1002*1171mm Net weight:180kg
包装尺寸Package size	包装尺寸:1800*1120*1136mm 毛重:260kg Package size:1800*1120*1136mm Gross weight:260kg

YXD-D450

www.yuxunda.com

深圳市宇讯达电子有限公司
SHENZHEN YUXUNDA ELECTRONICS CO., LTD

产品特点 PRODUCT FEATURES



■ 数码柯式烫画，一次成型，免刻，免镂空，免排废，无白边，环保。
Digital inkjet heat transfer, one time form, no carve, no hollow, no waste, no white edge, environment friendly.

■ 本机采用自动感应卷绕功能，省时、省力、省力。
The powder shaking machine adopts automatic induction winding function, which saves time and labor.

■ 废粉回收技术，避免浪费和节约成本。
Waste powder recycling technology, avoiding waste and saving cost.

■ 简单易用，打印+撒粉+烘干，一气呵成。
Simple and easy to use, printing, powder sparing and drying in 1.

产品参数

APPLICATION FIELD SCHEME

名称型号Model Name	DTF抖粉机D450 Powder Spraying Machine D450
收放介质宽幅Printing width	0-400mm
上粉控制Powder spraying control	抖粉控制，撒粉控制，方向，量的控制The control of shaking, spraying, direction and power
热烘干功能Heating function	前导板加热，上烘干固化，冷风降温功能Front heating, heating tube drying, cooling function
收卷功能Wind and rewind function	自动感应收卷Automatic induction rewind
电压/Voltage	220v 50Hz/60Hz
功率Power	功率: 2.3KW (能耗1KW-2.3KW) Power:2.3KW(rate power 1kw-2.3kw)
机器尺寸Machine size	机器尺寸:1730*610*750mm 净重:100kg Machine size:1730*610*750mm Net weight:100kg
包装尺寸Package size	包装尺寸:680*700*880mm 毛重:130kg Package size:680*700*880mm Gross weight:130kg

YXD-DTFA3

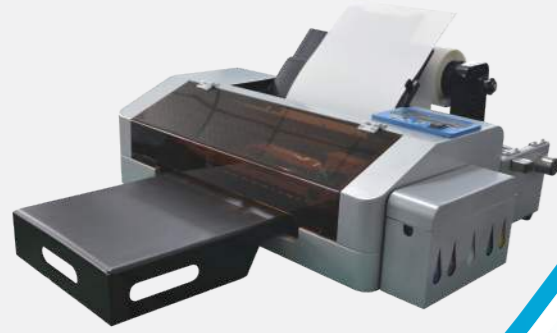

产品特点 PRODUCT FEATURES

- DTF打印机:(用于打印PET膜)
DTF printer: (for printing pet film)
- 全新升级, 不一样的设计, 卷材可批量生产打印/A3/A4
Fully upgraded, Exclusive design, Roll to roll mass production printer A3/A4
- 报警功能, 提醒您物品已完成, 无需一直注视。
Alarm function to remind you that the item has been completed and does not need to keep an eye on it.

产品参数 APPLICATION FIELD SCHEME

电压(Voltage)	220V/110V (50-60Hz)
打印精度(Printing resolution)	最高可达5760*1400dpi Up to 5760*1400dpi.
设备尺寸(Equipment Size)	840*595*320mm
电流(electric current)	2A
功率(Power)	35w
打印尺寸Print size	A3+卷材1000*300mm A3+ coil 1000*300mm
净重(Net Weight)	26kg
毛重(Gross Weight)	40kg
包装尺寸(Package Size)	910*670*450mm

YXD-L1800



产品类型:台式PET薄膜印刷 L1800 DTF打印机
Product type : Desktop PET film printing L1800 DTF printer

打印机型号:YXD-L1800
Printer model : YXD-L1800

印刷方式:喷墨印刷
Printing method : Inkjet printing

打印分辨率:5760dpi*1440dpi
Print resolution : 5760dpi* 1440dpi

水滴尺寸:1.5/2pi
drop size : 1.5/2pi

打印尺寸:A3或A4
Print size :A3 or A4

YXD-L805



产品类型:台式PET薄膜印刷L805 DTF打印机
Product type : Desktop PET film printing L805 DTF printer

打印机型号:YXD-L805
Printer model : YXD-L805

打印分辨率:5760dpi* 1440dpi
Print resolution : 5760dpi * 1440dpi

水滴尺寸:2pi
drop size : 2pi

墨水配置:6色
Ink configuration : 6 colors

打印尺寸:A4
Print size :A4

YXD-Y280



产品参数 APPLICATION FIELD SCHEME

名称Name	A3白墨固化烤箱Y280 A3 White ink fixation oven Y280
最大宽度(Max Width)	最大430*318mm Max430*318mm
适用介质Applicable medium	A3柯式烫画膜、墨水和胶粉的固化A3dtf film , ink and powder fuse
电压(Voltage)	额定电压220V,额定电流8.2A,额定功率1.8KW Rated voltage:220V.Rated current8.2A,Rated power-1.8KW
尺寸Size	机器:591*554*161mm 包装尺寸:670*580*200mm Machine: 591*554*161mm Package Size: 670*580*200mm
重量Weight	净重:14kg 毛重:16kg Net weight: 14kg Gross Weight: 16kg

产品特点 PRODUCT FEATURES

- 适合于A3/600mm膜白墨打印,墨水&粉的融合固化。
Suitable for A3/600mm film white ink printing .ink & powder fuse curing.
- 带来了自动计时和达到时蜂鸣和LED报警功能。
automatic timing, arrival buzzer and LED alarm.
- 第二代设计, 更科学结构, 温度更精确控制, 全宽干燥和固化, 无需死角, 完美的固化熔融效果。
Second generation design, more scientific structure, more accurate temperature control, full width drying and curing without dead corner. Perfect curing fusion effect.

产品参数 APPLICATION FIELD SCHEME

名称Name	600mm白墨固化烤箱Y380 600mm White ink fixation oven Y380
最大宽度(Max Width)	最大610*460mm Max610*460mm
适用介质Applicable medium	柯式烫画膜、墨水和胶粉的固化dtf film , ink and powder fuse
电压(Voltage)	额定电压220V,额定电流11A,额定功率2.4KW Rated voltage:220V.Rated current11A,Rated power2.4KW
尺寸Size	机器:890*573*165mm 包装尺寸:970*610*210mm Machine: 890*573*165mm Package Size: 970*610*210mm
重量Weight	净重:20kg 毛重:22kg Net weight: 20kg Gross Weight: 22kg

YXD-Y380



YXD-DTF 耗材



DTF打印膜
DTF Printing Film

墨水
INK

热熔粉
Hot Melt Powder

墨水
INK

进口
Import



白墨
White Ink



彩色
Colour

国产
Domestic



白墨
White Ink



彩色
Colour

热熔粉
Hot Melt Powder



DTF打印膜
DTF Printing Film



PET烫画膜 (单面/双面)
PET Hot stamping film
(single side/double side)
300/400/600mm



A4膜 (单面/双面)
A4 film (single side/double side)



A3膜 (单面/双面)
A3 film (single side/double side)

操作流程 OPERATION PROCESS

YXD-DTG/DTF Series (系列)

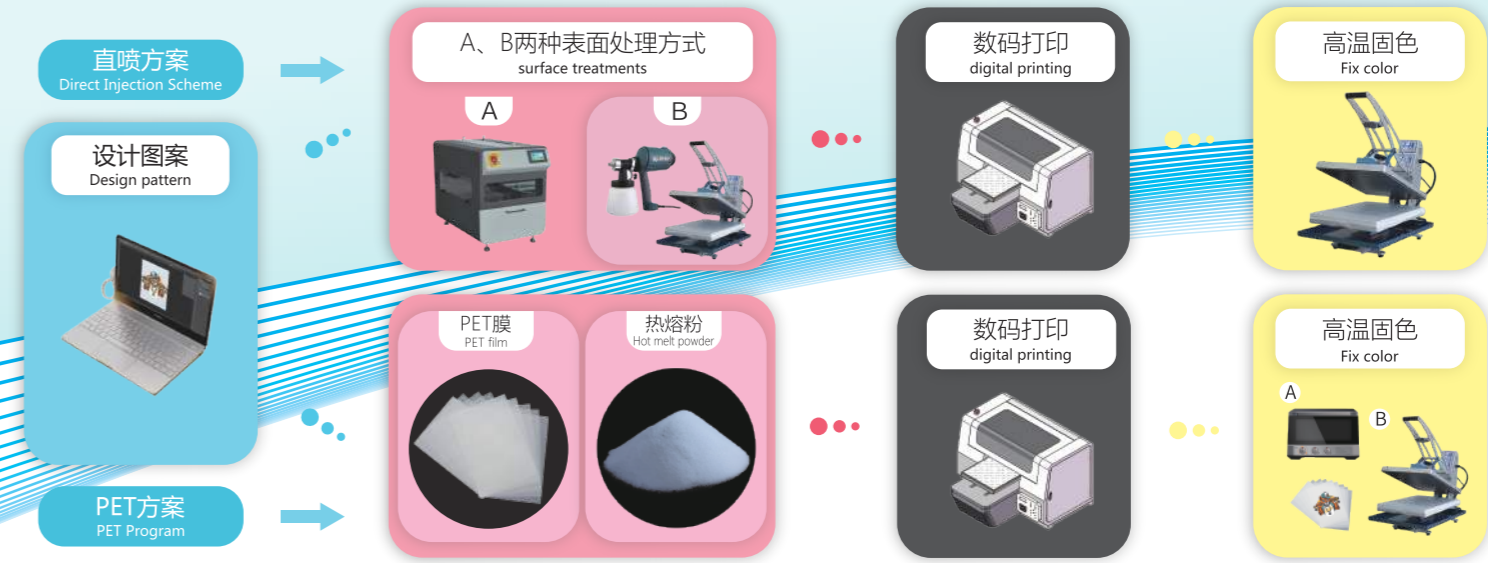
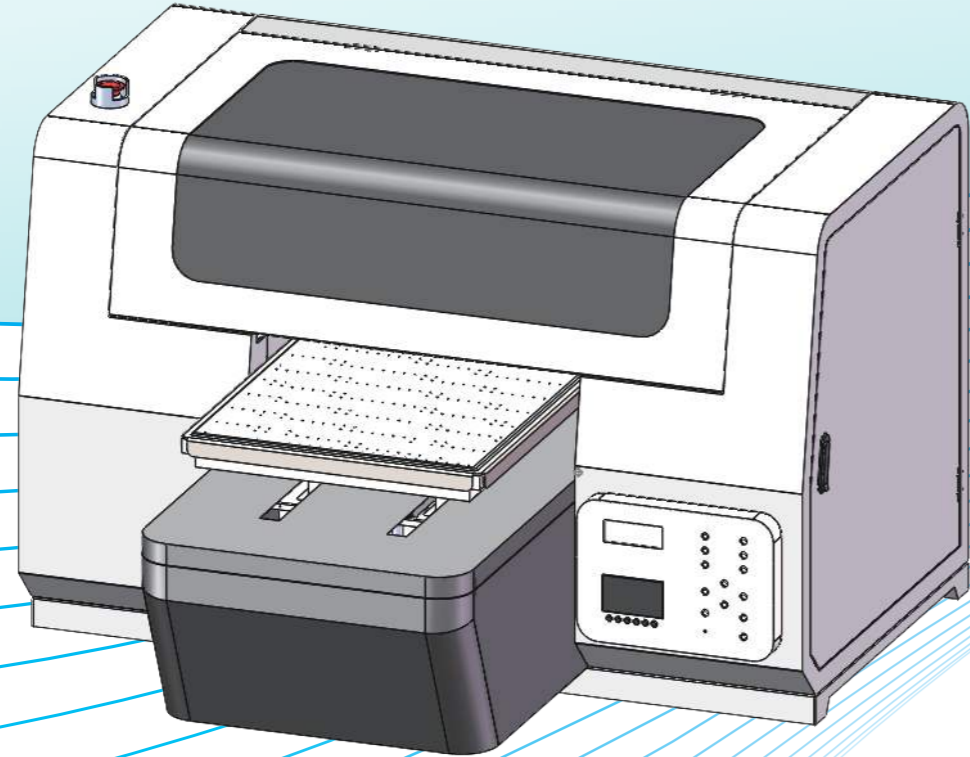

应用方案 APPLICATION SCHEME

深色衣服 DARK GARMENTS



打印深色衣服

4 pass: 80件/小时
6 pass: 50件/小时

For dark color garment

80 pieces / hour
50 pieces / hour

浅色衣服 LIGHT GARMENTS



打印浅色衣服

4 pass: 90件/小时
6 pass: 60件/小时

For light color garment

90 pieces / hour
60 pieces / hour

YXD-DTG/DTF (2 in 1)

www.yuxunda.com

深圳市宇讯达电子有限公司
SHENZHEN YUXUNDA ELECTRONICS CO., LTD

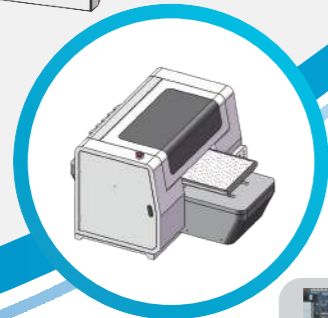
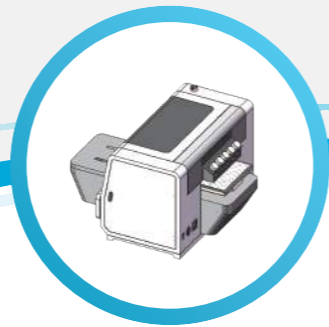
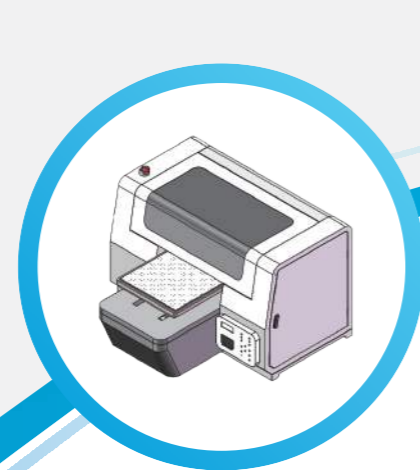
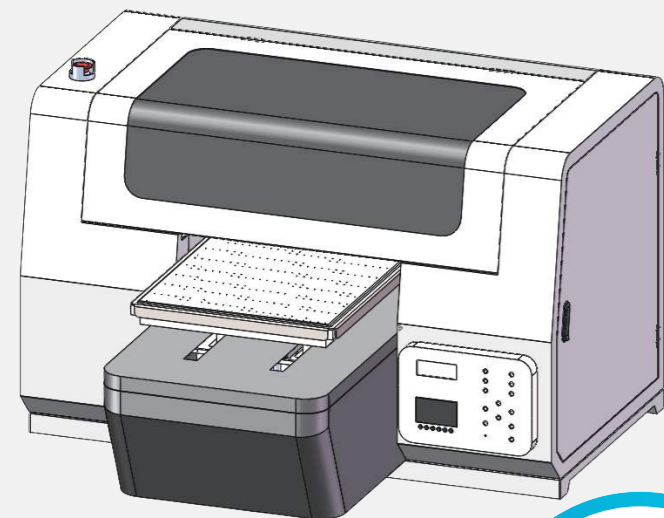

应用行业 APPLICATION INDUSTRY

适用介质: T恤, 化纤, 棉布, 皮革, 泳衣 卫衣, 环保袋, 抱枕, 帽子, 家纺布料。

Applicable medium: T-shirt, Polyster, Cotton, Leather, Swimwear, Sweatshirt, Suchion, Cap, Home, Texiiles.



产品特点 PRODUCT FEATURES

喷头 PRINT HEAD

白彩同出, 新一代EP喷头i3200, 实现高速打印。
Print white and colors simultaneously



汉森板卡 HOSON BOARD CARD

汉森高精度、高速度稳定网口板卡,打印细腻,喷画鲜艳。
Hoson high-precision, high-speed and stable network port board card, delicate printing, bright spray painting.



白墨循环系统 WHITE INK CIRCULATION SYSTEM

打印深色服装需要使用白色墨水, 长时间不使用易产生沉淀而堵塞喷头, 影响打印质量, 配备白墨自动循环系统, 有效防止墨水沉淀、减少墨水浪费、降低成本、并时刻保持一致的墨水浓度实现恒定的输出效果。
White ink is needed for dark garment, but easy to get sedimentation. The circulation system helps to prevent ink from sedimentation, save ink.

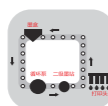

红外感应自动升降系统 INFRARED INDUCTION AUTOMATIC LIFTING SYSTEM

配备了红外线传感器, 可以精确的测量打印平台的高度是否超标, 自动调整打印平台的高度, 避免意外情况发生。
Equipped with infrared sensor to test and adjust the height of printing platform.



个性化定制 PERSONALIZED CUSTOMIZATION

白彩同出, 适用各种颜色、各种布料服装个性印花, 增强市场竞争力。
white and color print at the same time, Bright colors, suitable for a variety of fabrics, clothing printing.



产品参数 APPLICATION FIELD SCHEME

打印机型号(Printer model)	DTF/DTG(2in1)
打印技术(Printing technology)	压电式按需喷墨打印技术 (Piezoelectric inkjet printing technology)
墨水(Ink)	纺织颜料墨水 (Textile pigment ink)
颜色(Color)	5色:CMYK+白色 (5 color:CMYK+White)
最大打印范围(Maximum print size)	最大400mm*500mm (MAX 400mm*500mm)
供墨系统(Ink supply system)	白墨循环系统、白墨搅拌系统、白/彩独立清洗系统 (white ink circulation system, white ink stirring system, white/color independent cleaning system)
打印材料(Print material)	PET/100%纯棉、棉含量高的混纺100% (cotton, high cotton blend)
打印平台(Printing platform)	小号:250*300毫米 中号:350*400毫米 大号:400*500毫米 (Small:250*300mm Medium:350*400mm Large: 400*500mm)
支持图像格式(Support image format)	PNG/JPG/TIFF/BMP
打印精度(Printing resolution)	4pass 720*1800dpi 6 pass 720*2400dpi
系统支持(System Support)	XP/Win7/Win10
功率(Power)	工作功率200W待机功率50w (Working power 200W/standby power 50w)
最佳工作环境(Best working environment)	温度:22-30 °C湿度:40-60% (Temperature: 22-30 °C Humidity: 40-60%)
电源(Power supply)	AC110-240VAC,50/60Hz
尺寸(Size)	1115mm*1280mm*740mm
重量(Weight)	160KG

YXD-DTGS Series (系列)

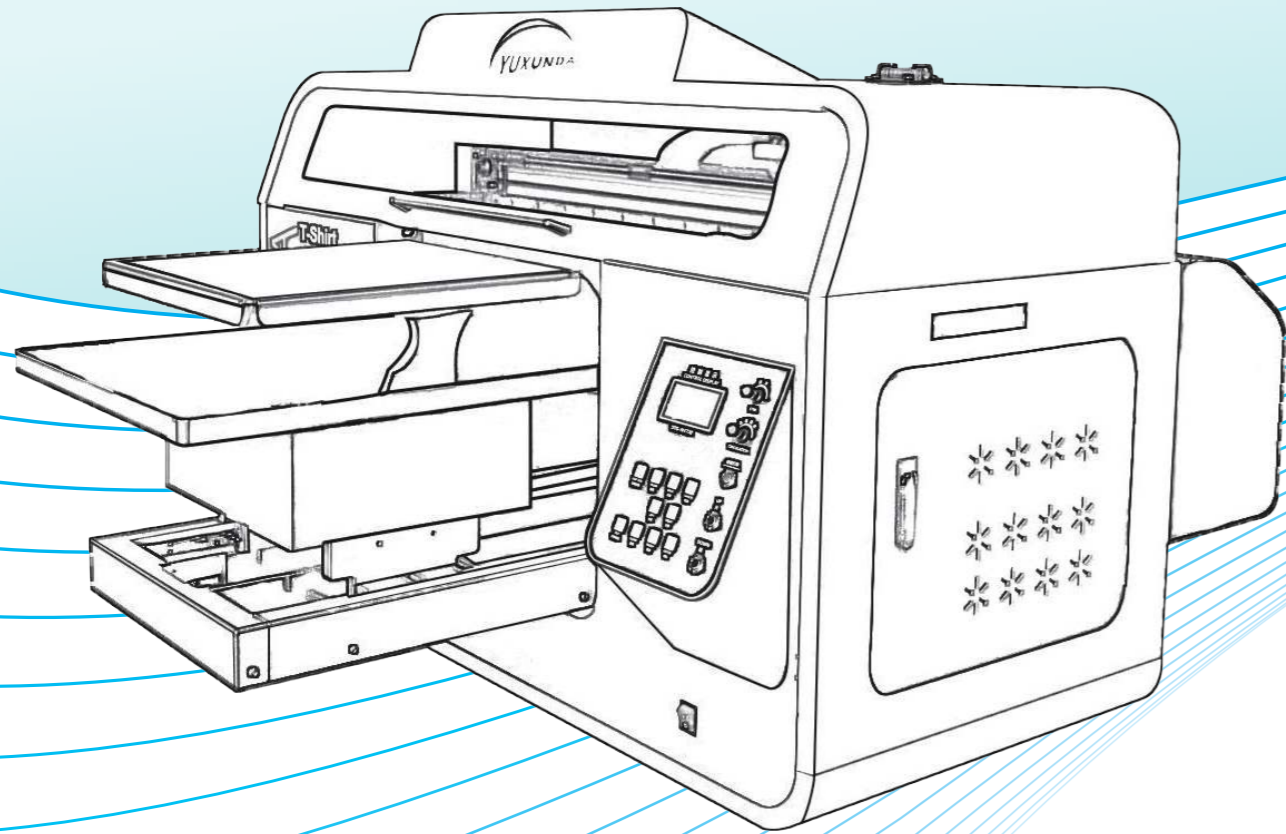

操作流程 OPERATION PROCESS

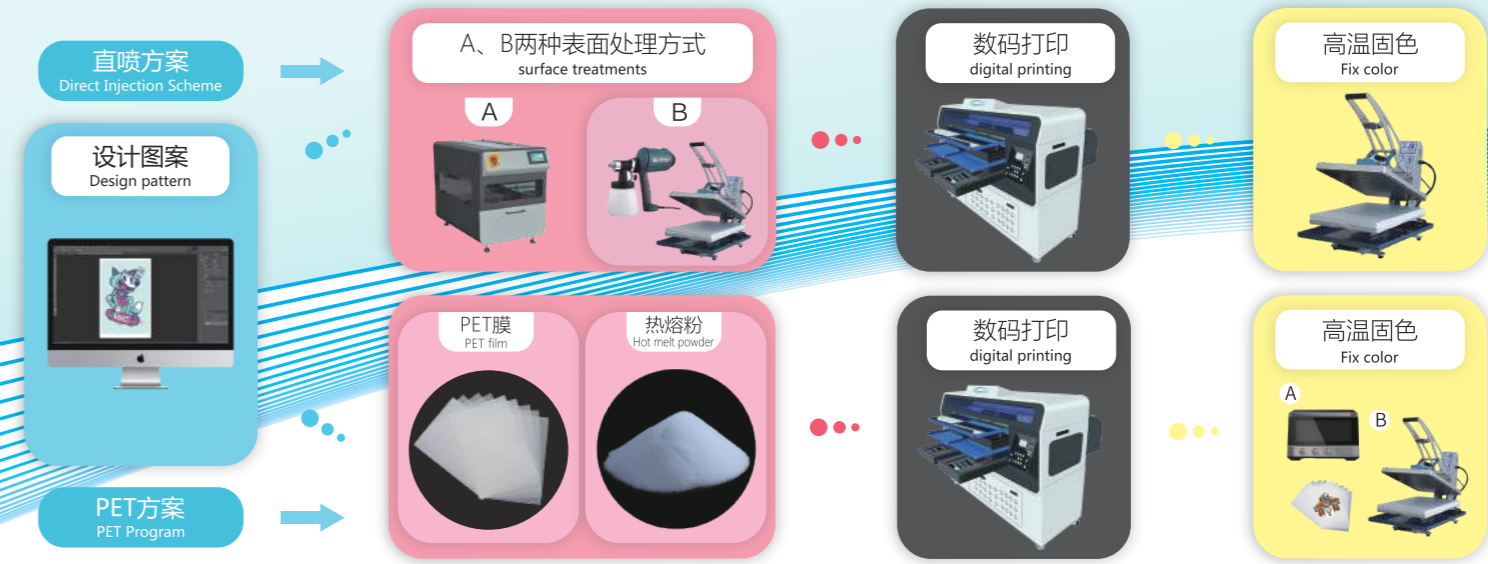

应用方案 APPLICATION SCHEME

<p>深色衣服 DARK GARMENTS</p>		<p>浅色衣服 LIGHT GARMENTS</p>							
<p>打印深色衣服 For dark color garment</p>					<p>打印浅色衣服 For light color garment</p>				
<p>4 pass: 80件/小时</p>		<p>80 pieces / hour</p>			<p>4 pass: 90件/小时</p>		<p>90 pieces / hour</p>		
<p>6 pass: 50件/小时</p>		<p>50 pieces / hour</p>			<p>6 pass: 60件/小时</p>		<p>60 pieces / hour</p>		

YXD-DTG405-1

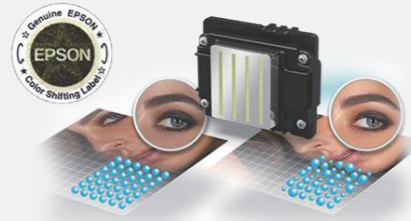

i3200-A1



产品特点 PRODUCT FEATURES



白墨循环系统 WHITE INK CIRCULATION SYSTEM

打印深色服装需要使用白色墨水，长时间不使用易产生沉淀而堵塞喷头，影响打印质量，配备白墨自动循环系统，有效防止墨水沉淀、减少墨水浪费、降低成本、并时刻保持一致的墨水浓度实现恒定的输出效果。
White ink is needed for dark garment, but easy to get sedimentation. The circulation system helps to prevent ink from sedimentation, save ink.



全新控制面板 NEW CONTROL PANEL

单工位控制面板包括连续打印功能，急停装置，白墨搅拌可调速功能，白墨循环可调速功能等。
Single-station control panel includes continuous printing function, emergency stop device, White ink stirring adjustable speed function, White ink circulation adjustable speed function, etc.



红外感应自动升降系统 INFRARED INDUCTION AUTOMATIC LIFTING SYSTEM

配备了红外线传感器，可以精确的测量打印平台的高度是否超标，自动调整打印平台的高度，避免意外情况发生。
Equipped with infrared sensor to test and adjust the height of printing platform.

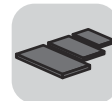

多种打印平台 MULTIPLE PRINTING PLATFORMS

最大可打印400mm*500mm，标配三种打印平台，满足不同打印尺寸的要求，平台的安装和更换过程极其简单。
Maximum printable 400mm*500mm, Three platforms are offered, different sizes, easy changable.



喷头 PRINT HEAD

白彩同出，新一代EP喷头i3200，实现高速打印。
Print white and colors simultaneously

应用行业 APPLICATION INDUSTRY

适用介质：T恤，化纤，棉布，皮革，泳衣 卫衣，环保袋，抱枕，帽子，裤子，家纺布料。

Applicable medium: T-shirt, Polyester, Cotton, Leather, Swimwear, Sweatshirt, Suchion, Cap, Pants, Home, Textiles.



产品参数 APPLICATION FIELD SCHEME

打印机型号(Printer model)	YXD-DTG450-1 (单工位)
打印技术(Printing technology)	压电式按需喷墨打印技术 (Piezoelectric inkjet printing technology)
墨水(Ink)	纺织颜料墨水 (Textile pigment ink)
颜色(Color)	5色:CMYK+白色 (5 color:CMYK+White)
最大打印范围(Maximum print size)	最大400mm*500mm (MAX 400mm*500mm)
供墨系统(Ink supply system)	白墨循环系统、白墨搅拌系统、白/彩独立清洗系统(white ink circulation system, white ink stirring system, white/color independent cleaning system)
打印材料(Print material)	100%纯棉、棉含量高的混纺100% (cotton, high cotton blend)
打印平台(Printing platform)	小号:250*300毫米 中号:350*400毫米 大号:400*500毫米 (Small:250*300mm Medium:350*400mm Large: 400*500mm)
支持图像格式(Support image format)	PNG/JPG/TIFF/BMP
打印精度(Printing resolution)	4pass 720*1800dpi 6pass 720*2400dpi
系统支持(System Support)	XP/Win7/Win10
功率(Power)	工作功率200W待机功率50w (Working power 200W/standby power 50w)
最佳工作环境(Best working environment)	温度:22-30℃ 湿度:40-60% (Temperature: 22-30℃ Humidity: 40-60%)
电源(Power supply)	AC110-240VAC,50/60Hz
尺寸(Size)	1120mm*1382mm*1280mm
重量(Weight)	160KG

YXD-DTG405-2

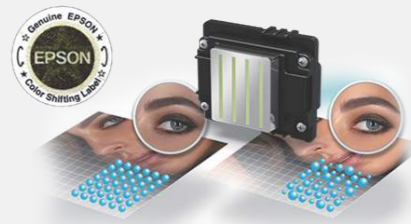

i3200-A1



产品特点 PRODUCT FEATURES

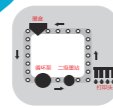

白墨循环系统 WHITE INK CIRCULATION SYSTEM

打印深色服装需要使用白色墨水，长时间不使用易产生沉淀而堵塞喷头，影响打印质量，配备白墨自动循环系统，有效防止墨水沉淀、减少墨水浪费、降低成本、并时刻保持一致的墨水浓度实现恒定的输出效果。
White ink is needed for dark garment, but easy to get sedimentation. The circulation system helps to prevent ink from sedimentation, save ink.



全新控制面板 NEW CONTROL PANEL

单工位控制面板包括连续打印功能，急停装置，白墨搅拌可调速功能，白墨循环可调速功能等。
Single-station control panel includes continuous printing function, emergency stop device, White ink stirring adjustable speed function, White ink circulation adjustable speed function, etc.



红外感应自动升降系统 INFRARED INDUCTION AUTOMATIC LIFTING SYSTEM

配备了红外线传感器，可以精确的测量打印平台的高度是否超标，自动调整打印平台的高度，避免意外情况发生。
Equipped with infrared sensor to test and adjust the height of printing platform.

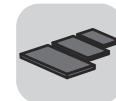

多种打印平台 MULTIPLE PRINTING PLATFORMS

最大可打印400mm*500mm，标配三种打印平台，满足不同打印尺寸的要求，平台的安装和更换过程极其简单。
Maximum printable 400mm*500mm, Three platforms are offered, different sizes, easy changable.



喷头 PRINT HEAD

白彩同出，新一代EP喷头i3200，实现高速打印。
Print white and colors simultaneously

应用行业 APPLICATION INDUSTRY

APPLICATION INDUSTRY

适用介质：T恤，化纤，棉布，皮革，泳衣 卫衣，环保袋，抱枕，帽子，家纺布料。

Applicable medium: T-shirt, Polyester, Cotton, Leather, Swimwear, Sweatshirt, Suchion, Cap, Home, Textiles.



产品参数 APPLICATION FIELD SCHEME

APPLICATION FIELD SCHEME

打印机型号(Printer model)	YXD-DTG450-2 (双工位)
打印技术(Printing technology)	压电式按需喷墨打印技术 (Piezoelectric inkjet printing technology)
墨水(Ink)	纺织颜料墨水 (Textile pigment ink)
颜色(Color)	5色:CMYK+白色 (5 color:CMYK+White)
最大打印范围(Maximum print size)	最大400mm*500mm (MAX 400mm*500mm)
供墨系统(Ink supply system)	白墨循环系统、白墨搅拌系统、白/彩独立清洗系统 (white ink circulation system, white ink stirring system, white/color independent cleaning system)
打印材料(Print material)	100%纯棉、棉含量高的混纺100% (cotton, high cotton blend)
打印平台(Printing platform)	小号:250*300毫米 中号:350*400毫米 大号:400*500毫米 (Small:250*300mm Medium:350*400mm Large: 400*500mm)
支持图像格式(Support image format)	PNG/JPG/TIFF/BMP
打印精度(Printing resolution)	4pass 720*1800dpi 6pass 720*2400dpi
系统支持(System Support)	XP/Win7/Win10
功率(Power)	工作功率200W待机功率50w (Working power 200W/standby power 50w)
最佳工作环境(Best working environment)	温度:22-30℃ 湿度:40-60% (Temperature: 22-30℃ Humidity: 40-60%)
电源(Power supply)	AC110-240VAC,50/60Hz
尺寸(Size)	1590mm*1382mm*1280mm
重量(Weight)	260KG

YXD-PL430

www.yuxunda.com

深圳市宇讯达电子有限公司
SHENZHEN YUXUNDA ELECTRONICS CO., LTD



产品特点 PRODUCT FEATURES



5.Pretreatment liquid color switching valve
Simple control and clear goals



3.Spray area regulating valve
Save liquid, the maximum spraying range 50cm adjustable



2.Waste discharge pipe
Release waste liquid to avoid corrosion



1.High-pressure atomizing nozzle
American brand original nozzle, removable for cleaning



4.Built-in liquid bottle
Pretreatment liquid bottle: 2*5000ml
cleaning liquid bottle: 1*1000ml



6.Extension Pipe
Save the time of transferring liquid to the built-in bottle



7.display screen

- ① Support display content Chinese/English switching
- ② set sprays volume The spraying ink volume is adjustable from 10ml-100ml, and the spraying volume can be flexibly set according to the characteristics of different fabrics. The light-colored T-shirt is set to 40ml, and the dark-colored T-shirt is set to 45ml, which is the best solution (factory setting solution)
- ③ The nozzle cleaning function effectively avoids the nozzle clogging after the work , and the color mixing caused by the rest pretreatment liquid of different colors
- ④ Record the spraying time of each T-shirt and the number of sprayed T-shirts, so that you can clearly manage your work efficiently (click to clear)
- ⑤ Dark and light pretreatment liquid can be switched at will, and the color of the treatment liquid currently set to be sprayed will be displayed to let you know your choice

应用行业 APPLICATION INDUSTRY

适用介质: T恤, 化纤, 棉布, 皮革, 泳衣 卫衣, 环保袋, 抱枕, 帽子, 家纺布料。

Applicable medium: T-shirt, Polyster, Cotton, Leather, Swimwear, Sweatshirt, Suchion, Cap, Home, Textiiles.



产品参数 APPLICATION FIELD SCHEME

型号model	YXD-PL430
喷嘴数Number of Spray nozzle	1个 1PCS
喷嘴品牌Nozzle Brand	美国USA
喷嘴技术Nozzle Technology	高压雾化技术High pressure Atomization Spay Technology
喷嘴控制技术Nozzle Control Technology	自动流量控制Automatic flow drop control
控制固件系统Control Firmware System	PLC编程系统PLC programming system
喷涂速度Spray Speed	Light color 5 seconds per T-shirt 40ml/dark color 6 seconds per T-shirt 45ml (420mm x520mm size)
喷雾路径长度Spray Path Length	可调至50mm(Adjustable up to 50mm)
标准压板尺寸Standard Platen Size	430mm x550mm尺寸(size 430mm x550mm)
喷雾路径运动Spray Path Motion	10ml~100ml可调(10ml~100ml adjustable)
喷雾流量Spray Flow	(3 kinds (dark T-shirt pretreatment, light T-shirt pretreatment, cleaning solution) (Note: there are only 2 channels now)
液体转化Liquid Tank Capacity	自动电磁阀控制Automatic Electromagnetic Valve Control
液罐容量Electrical Re quirements	每次5000毫升, 共2罐/清洗液1000毫升(5000 ml each time, a total of 2 cans/1000 ml of cleaning solution)
电压/功率Transmission Type	220V/110V (50HZ/60HZ) 150W
净重Packing Weight 包装重量Packing Weight	59Kg 90Kg
机器尺寸Machine Size 包装尺寸Packing Size	905*580*750mm 955*625*880mm

YXD-DTGT 耗材

墨水
INK

处理液
TREATMENT
FLUID

墨水
INK

进口
Import



杜邦白墨
DuPont White Ink

杜邦彩墨
DuPont Color Ink

国产
Domestic



白墨
White Ink



彩墨
Color Ink

处理液
TREATMENT
FLUID

